

CLEARLAKE OAKS COUNTY WATER DISTRICT

NOTICE OF A REGULAR MEETING OF THE BOARD OF DIRECTORS

Date: August 17, 2023

Time: 2:00 P.M.

Clearlake Oaks County Water District Administration Building
12952 E. Hwy. 20 Clearlake Oaks, CA 95423

AGENDA

A. CALL TO ORDER

- Pledge of Allegiance
- Roll Call

- Mr. Stanley Archacki, President Mr. Michael Herman, Vice President Mr. Samuel Boucher, Director
- Mr. James Burton, Director Mr. William McHugh, Director Mrs. Dianna Mann – General Manager
- Mrs. Olivia Mann – Board Secretary

- Mr. Francisco Castro, Wastewater Mr. Kurt Jensen, Water Mr. Jeremy Backus, Distribution

B. PUBLIC COMMENT ON ITEMS NOT ON THE AGENDA

The public may comment on items not on the agenda within the Board's jurisdiction. Speakers are limited to three (3) minutes each.

C. STAFF REPORTS

1. Administration
2. Chief Distribution Operator - Unavailable
3. Chief Water Plant Operator
4. Chief Wastewater Plant Operator
5. General Manager

D. CONSENT ITEMS

The Board will be asked to approve all Consent Items at one time without discussion. If any Director, staff, or interested person requests that an item be removed from the Consent Items, it will be considered under New Business.

1. **Financial Reports for review and approval**
 - a. July 2023 QB balance sheet and profit & loss statements
 - b. Bank account balances and accounts receivable
 - c. Employee payroll report
 - d. Aged trial balance summary
 - e. Vendor aging report, accounts payable breakdown

2. **Minutes of previous meeting for review and approval**
 - a. Minutes of Regular Meeting 07/20/2023 (**Page 40**)

3. **Bills**

- a. MC Engineering invoice number 2437, dated 8/5/23, in the amount of \$8,747.50 for the SWRCB Water TA Grant *(Page 44)*

Action Taken: _____

E. OLD BUSINESS

- 1. Discussion of Fire Protection

Action Taken: _____

F. NEW BUSINESS

- 1. Discussion and consideration of Revised Lake Fleet Repair & Tow Invoice #002373 in the amount of \$13,035.71 *(Page 45)*

Action Taken: _____

- 2. Discussion and consideration of Quote from Ryan Process, Inc. in the amount of \$20,468.50 for the Chlorine Tank at the WWTP *(Page 47)*

Action Taken: _____

- 3. Discussion and consideration of Resolution 23-11, Transferring Delinquent Account Balance to the Lake County Tax Roll *(Page 50)*

Action Taken: _____

- 4. Discussion and consideration of Resolution 23-12, Authorizing Investment of Monies in the Local Agency Investment Fund *(Page 52)*

Action Taken: _____

G. CLOSED SESSION

Time:

- 1. Pending Litigation: One Case
- 2. Potential Litigation: One Case

Action Taken: _____

Open Session

Time:

ADJOURNMENT

Time:

Where appropriate or deemed necessary, the Board may take action on any item listed on the agenda, including items listed as information items. Public documents relating to any open session item listed on this agenda that are distributed to all or a majority of the members of the Board of Directors less than 72 hours before the meeting are available for public inspection in the customer service area of the District's Administrative Office at the above address.

The public may address the Board concerning an agenda item during the Board's consideration of that

agenda item. The President will call for comments at the appropriate time. Comments of individual speakers are limited to three minutes per agenda item.

In compliance with the Americans with Disabilities Act, if you have a disability, and you need a disability-related modification or accommodation to participate in this meeting, then please contact Clearlake Oaks County Water District Secretary to the Board at 707-998-3322. Requests must be made as early as possible, and at least one full business day before the start of the meeting.

Clearlake Oaks County Water District

P.O. Box 709 / 12952 East Highway 20
Clearlake Oaks, CA 95423
(707) 998-3322 Phone (707) 998-1245 Fax
www.clocwd.org (Website)

August 11, 2023

Administration

- ∂ We received 0 water quality complaints (WQC).
- ∂ We received 0 consumer/appeal claim(s).
- ∂ There are 10 accounts on payment arrangements.
 - We continue to receive payments from the LIHWAP program for past due balances, we are also referring customers to contact the program. To date, we have received \$15,435, this amount has prevented services from being shut off and has also restored services. *Please note, this amount has not changed in the last 30 days.*
- ∂ BPA testing is making slow progress, we have tested 725 devices, there are 227 devices remaining, testing will conclude on December 31, 2023.
 - This is only a 2 device difference from last month
- ∂ On August 10, 2023, I submitted \$165,789.82 in direct charges over 125 different accounts, Resolution 23- 11 is on the agenda authorizing these assessments
- ∂ We have made huge progress with Docufree's access portal. Although not everything has been shipped to them yet, our access to the APN files has been huge. I know we have only scratched the surface on what this program has to offer.
 - I really want to bring shipping the remaining boxes to the forefront and make more strides towards being paperless!
- ∂ I have booked the CSDA conference for Dianna and I to attend, we were able to book 1 class already and view all the other classes available, all returning attendees have a NEW class lineup and we are very excited. Additionally, we were featured in the brochure this year!

Olivia Mann
Administrative Services Manager
Board Secretary

Stanley Archacki
President

Michael Herman
Vice President

Samuel Boucher
Director

James Burton
Director

William McHugh
Director

A

Aged Accounts Receivable

As of 08/14/2023 (AM)

	1-30 Days	31-60 Days	61-90 Days	91-120 Days	<120 Days	Total Balance
	\$122,165.64	\$38,818.79	\$18,997.08	\$18,524.64	\$251,936.48	\$450,442.63
No. of Accounts:	935	331	217	153	238	1874

These totals include all accounts on the Tax Roll

Water	\$132,994.18
Water Penalty	\$10,018.16
Sewer	\$157,630.09
Sewer Penalty	\$10,921.01
CRP Water	\$56,955.07
CRP Water Penalty	\$4,469.87
CRP Sewer	\$71,901.42
CRP Sewer Penalty	\$4,856.67
CRP PC	\$663.56
CRP PC Penalty	\$32.60
Total Balance:	\$450,442.63

July Statements are due August 15, 2023

Clearlake Oaks County Water District

P.O. Box 709 / 12952 East Highway 20
Clearlake Oaks, CA 95423
(707) 998-3322 Phone (707) 998-1245 Fax
www.clocwd.org (Website)

August 2023

Board letter

- ◆ July raw water NTU from the extended intake has primarily in the range of 5-10 with spikes up to 20. The PH level has remained in the range between 8.5 -9. Charge analyzer and jar testing are being done regularly; adjustments are being made and monitored to keep up with PH changes.
- ◆ The lake is currently at 4.19 down 1.16 ft from previous report.
- ◆ Water production for the month of July 2023 was 22.121 MG. Raw water intake is 26.848 MG. Down from July 2022 production of 22.503 MG. Production has increased over the last month and has been averaging 713,000 GPD.
- ◆ We are still getting plant shut downs.
- ◆ Treatment has been able to do the weekly tank runs for testing of chlorine residuals in all the tank locations.
- ◆ Continuing maintenance / cleanup through the plant area.
- ◆ Filters 2 and 3 continue online paired with the extended intake keeping NTU numbers down.
- ◆ TTHM sampling and flushing are still being completed. Samples are being taken at the Harvey tank, as Harvey feeds the Paradise tank. Results of the test are attached
- ◆ Water sample list is attached
- ◆ We had an OSHA walk through. We have been working on the list of corrections they provided. All but one of the items has been completed. Pictures attached. Screens covers where added to high service pump motors, screens where also added to filter pump motors and raw water pump. A cabinet safety latch and screens where added to clarifier cabinets. A hand rail extension was also installed on the clarifier hand rails. Various electrical fixes where completed also, removal of extension cord replaced with conduit and new plug, knock outs that were missing where replace or repaired. One project is left from this. It will be installing a safety rail on the sea wall.

Stanley Archacki
President

Michael Herman
Vice President

Samuel Boucher
Director

James Burton
Director

William McHugh
Director

u

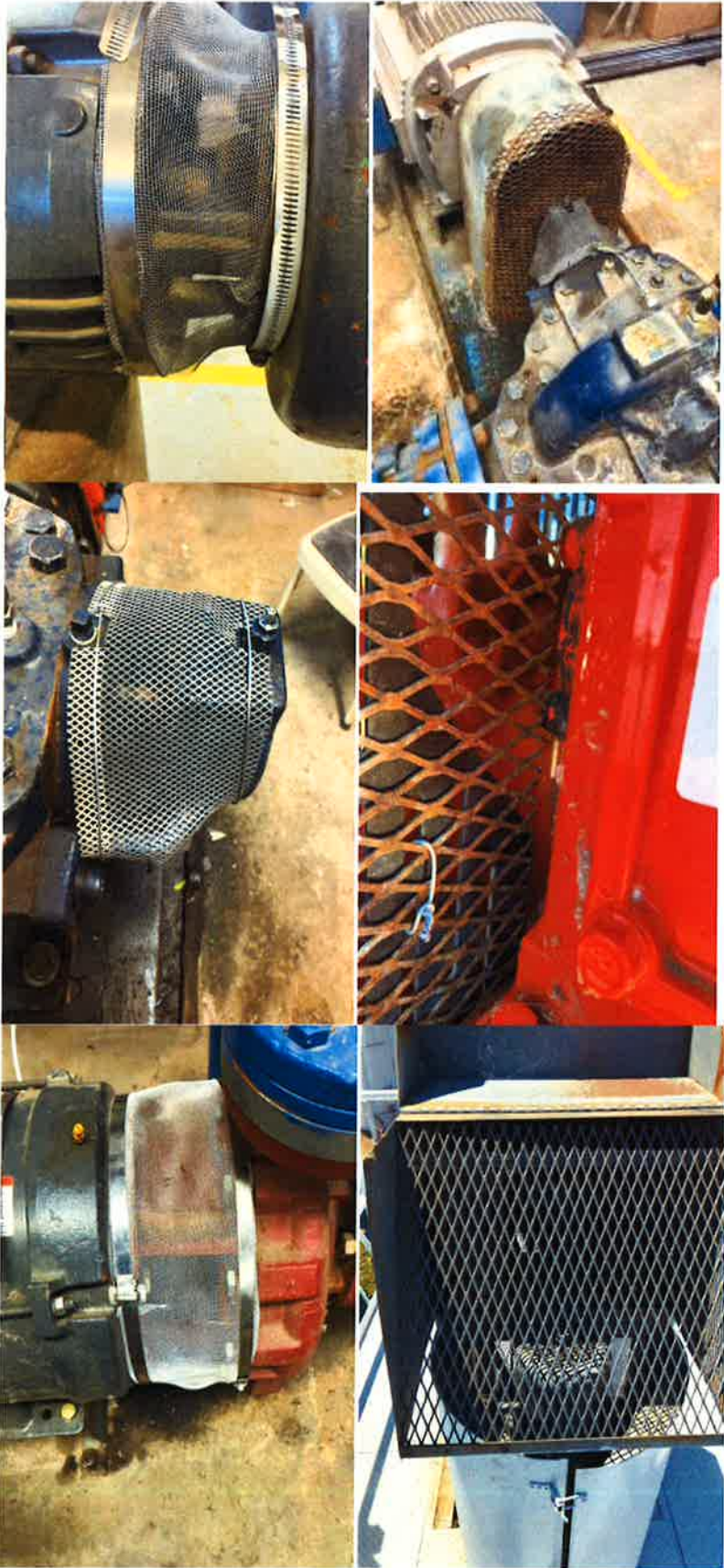

Stanley Archacki
President

Michael Herman
Vice President

Samuel Boucher
Director

James Burton
Director

William McHugh
Director





Stanley Archacki
President

Michael Herman
Vice President

Samuel Boucher
Director

James Burton
Director

William McHugh
Director



Stanley Archacki
President

Michael Herman
Vice President

Samuel Boucher
Director

James Burton
Director

William McHugh
Director



Treatment staff:

James Simons T3 Operator Class B permit

Kurt Jensen T3, D2 Chief Class B License

Helping treatment also

Jesse Seth T2 D3 operator

Thank you,

Kurt Jensen

WTP Chief Plant Operator

k.jensen@clowd.org

Water Sample Testing

	DATE	DATE	DATE
Bacti R(BW) & CW (M)	7/5/2023	8/2/2023	
Bacti R (BW)	7/20/2023		
Bacti Tank Farm (once)			
R & CW TCP123 (BA)			
Color / Odor (A)			
Cyano Toxin(W)			
Bromate (Q)			
Perchlorate (A)			
TTHM (Q)	7/6/2023	7/20/2023	
HAA5 (Q)	7/6/2023	7/20/2023	
Lead & Copper (A)(1)			
Lead & Copper (A)(1)			
Lead & Copper (A)(1)			
Nitrate (A)			
Nitrite (A)			
Antimony (A)			
Arsenic(A)			
Barium(A)			
Beryllium(A)			
Cadmium(A)			
Chromium Total (A)			
Fluoride Natural(A)			
Mercury(A)			
Nickel(A)			
Selenium(A)			
Thallium(A)			
Simazine(A)			
Bicarbonate Alaklinity(A)			
Calcium(A)			
Carbonate Alakalinity(A)			
Chloride(A)			
Copper(A)			
Foaming Agents (MBAS)(A)			
Hardness Total as CaCO3(A)			
Hydroxide Alakalinity(A)			
Iron(A)			
Magnesium(A)			
Manganese(A)			
PH, Laboratory(A)			
Silver(A)			
Sodium(A)			
Specific Coductance(A)			
Sulfate(A)			

A = Annually
 Q = Quarterly
 M = Monthly
 W = Weekly

***Please note:
 December is a
 large sampling
 month there will
 many samples
 taken this month***

Total Dissolved Solids(A)				
Turbidity, Laboratory(A)				
Zinc(A)				
Aluminum(A)				
MTBE(A)				
Color / Odor				
Asbestos				semi annually
Thiobencarb(A)				
Ethylene Dibromide				Every 9 Years
Heptachlor				Every 9 Years
Heptachlor Epoxide				Every 9 Years
BHC-Gamma				Every 9 Years
Methoxychlor				Every 9 Years
Toxaphene				Every 9 Years
Clearwell VOC				
Reg SOC 504 EDB				
Bacti clearwell				
Regulated SOC 504				
Thiobencarb				

Clearlake Oaks County Water District

P.O. Box 709 / 12952 East Highway 20
Clearlake Oaks, CA 95423
(707) 998-3322 Phone (707) 998-1245 Fax
www.clocwd.org (Website)

August 14, 2023

Clearlake Oaks County Water District
P.O. Box 709
Clearlake Oaks, CA 95423-0709

RE: July Board Letter

FLows FOR THE MONTH/CLEARLAKE LAKE LEVEL:

- ❖ **INFLUENT: 15.236 MG (AVERAGE:491,000 GPD)**
- ❖ **EFFLUENT: 13.131 MG (AVERAGE: 424,000 GPD/294 GPM)**
- ❖ **CLEARLAKE AVERAGE LEVEL: 5.34' RUMSEY GAUGE**

As Clearlake begins to drop, our flows to the plant does as well. There was 2.618 MG less this month as compared to June. Clearlake dropped an average 1.10'. The plant process has been going well. Our settling around this time of season begins to be affected by algae coming from the water plant. We don't expect it to be as bad as the last two years and so far it has not been. The sodium hypochlorite bulk tank has come to its end. It is urgent we move forward with purchasing a new one. At this time there is a inner leak into the containment tank. I have submitted a quote to purchase a new Snyder Tank from one of our vendors Ryan Processes.

On the 10th we had an OSHA non reportable inspection. Minor things were pinpointed as urgent corrections. We were given 30 days to correct such thing and given the option on an extension of 30 more days. We were able to complete 95% of the corrections. A extension was requested to fully complete all corrections.

We would like to welcome Garrett Swanz as a permanent operator at the waste plant. Anthony Casanova has resigned and has moved on with his career somewhere else. We are happy to have Garrett on board. Again we thank the board for the support given us operators.

Francisco Castro
CPO Wastewater Plant

Stanley Archacki
President

Michael Herman
Vice President

Samuel Boucher
Director

James Burton
Director

William McHugh
Director

13

Clearlake Oaks County Water District
Board of Directors
Board Meeting August 17, 2023

Board of Directors,

The completed Cal-Osha reports were forwarded to all Board members showing the violations and the corrective actions taken by Staff. I am pleased to say that staff completed all violations except one at each plant within the 30 days. We have requested an extension for the remaining violations that will be completed once material arrives.

As most of you already know, the District is going through a State audit on the Inflow and Infiltration grant that dates back to 2016. This has taken most of my time in the last two weeks providing all the requested documents and zoom meetings. I believe the audit should go well, however, we might be dinged on a couple of internal controls. Even though this audit is a major headache with all the time it is requiring, I am looking at it as a learning experience and will use their recommendations on future grants.

Some of you were present at the East Region Town Hall meeting that was held on August 2nd, where I was invited as the guest speaker. Thank you for your support. I explained the recent upgrades to the District, future plans, and answered some questions. Overall it went pretty well.

I have transferred money from the LAIF account into General Ledger in preparation for the wire transfer that is scheduled for August 17th.

The District has had a couple of fires in the past month, Staff continues to support the fire fighters at the scene.

Leaks continue, a never ending story. I believe we had three leaks in one day that kept staff very busy, however, like champs, all were fixed.

Still working with insurance on the repair of our Water Plant fence.

Want to throw a shout out to Francisco and congratulate him on his 10th year anniversary with the District.

As always, I want to thank the staff for a job well done.

Dianna Mann
General Manager

Clearlake Oaks County Water District

Summary Balance Sheet

As of July 31, 2023

	Jul 31, 23
ASSETS	
Current Assets	
Checking/Savings	1,886,723.68
Accounts Receivable	204,087.00
Other Current Assets	2,943,233.37
Total Current Assets	5,034,044.05
Fixed Assets	23,282,419.97
TOTAL ASSETS	28,316,464.02
LIABILITIES & EQUITY	
Liabilities	
Current Liabilities	
Accounts Payable	61,038.38
Credit Cards	140.62
Other Current Liabilities	8,457,570.50
Total Current Liabilities	8,518,749.50
Long Term Liabilities	661,689.59
Total Liabilities	9,180,439.09
Equity	19,136,024.93
TOTAL LIABILITIES & EQUITY	28,316,464.02

Clearlake Oaks County Water District
Balance Sheet
As of July 31, 2023

	Jul 31, 23
ASSETS	
Current Assets	
Checking/Savings	
102.14 · CalPERS RESERVE - 7355	88,351.17
102.13 · SEWER RESERVES-9592	137,994.43
102.10 · CRP PC - 6192	98,605.34
102.12 · WATER RESERVES- 8503	174,949.73
102.001 · GL - 9122 (Old Acct. # 053420019)	92,280.51
101 · LAIF - CASH IN BANK (CASH IN BANK - LAIF - WAS 1013550)	
CIP Deposits 2014	189,000.00
101 · LAIF - CASH IN BANK (CASH IN BANK - LAIF - WAS 1013550) - Other	892,993.12
Total 101 · LAIF - CASH IN BANK (CASH IN BANK - LAIF - WAS 1013550)	1,081,993.12
102.01 · WEST AMERICA - REGULAR CHECKING (WEST AMERICA BANK C...	88.98
102.02 · CRP Water - 6990	92,859.08
102.03 · CRP Sewer - 3745	119,601.32
Total Checking/Savings	1,886,723.68
Accounts Receivable	
CUSI Accounts Receivable	204,087.00
Total Accounts Receivable	204,087.00
Other Current Assets	
139 · Docufree (Purchasing space on the Cloud xfering hard copies)	28,727.90
116 · DEFERRED OUTFLOW- PENSION	282,829.00
103 · PETTY CASH (PETTY CASH - WAS 1013200)	306.59
104 · COUNTY TREASURY (COUNTY TREASURY - WAS 1013201)	26,664.68
130 · Const In Progress - Studies	
130.97 · Const in Progress - Actiflo Pii (Actiflo Pilot Program)	3,280.00
130.96 · Const in Progress - WWP 2022 (Grant application for WWTP for ...)	4,670.00
130.95 · Source Capacity Studygrant prep	9,859.00
130 · Const In Progress - Studies - Other	688,182.94
Total 130 · Const In Progress - Studies	705,991.94
132 · CRP SEWER (CAPITOL IMPROVEMENTS - SEWER - WAS 1199200)	983,511.67
135 · CRP WATER (CAPITOL IMPROVEMENTS - WATER - WAS 1199100)	249,148.33
114 · ACCOUNTS RECEIVABLE. (ACCOUNTS RECEIVABLE - WAS 1097010)	650,661.26
115 · PRE-PAID INSURANCE (PRE-PAID INSURANCE - WAS 1097840)	15,392.00
Total Other Current Assets	2,943,233.37
Total Current Assets	5,034,044.05
Fixed Assets	
136 · CUSI Software (All expenses related to billing software)	13,172.00
138 · USDA Water Improvements	8,199,063.97
128 · Sewer Infrstrcture & Rehab Proj (Phase 1 was the installation of the Forc...	3,890,219.87
121 · Wtr Dist & Wtr Storage Projects (Replacement or installation of water dis...	
121.1 · Sidewalk Project - District Exp	115,500.66
121 · Wtr Dist & Wtr Storage Projects (Replacement or installation of water ...)	277,266.74
Total 121 · Wtr Dist & Wtr Storage Projects (Replacement or installation of wat...	392,767.40
131 · Waste Water Plant	
131.1 · Pumps/Equipment	143,307.20
131 · Waste Water Plant - Other	230,059.50
Total 131 · Waste Water Plant	373,366.70
126 · Forcemain (phase 1) Cap. Imprv.	1,233,797.22
123 · USDA - Sewer Plant Cap Imprvmt	4,265,559.43
USDA Project	-523,819.00
127 · Water Plant	
127.7 · Ozone System	12,785.71
127.6 · Swan AMI Turbiwell Monitor	25,079.10
127.5 · A/C installation for Filter Rm	750.00
127.4 · PH System	9,959.72
127.2 · Harvy Vault Chlor Inject Proj	1,408.61

11

Clearlake Oaks County Water District
Balance Sheet
As of July 31, 2023

	Jul 31, 23
127.1 · Major Equipment	357,521.21
127 · Water Plant - Other	211,458.66
Total 127 · Water Plant	618,963.01
120 · District General CRP (EQUIPMENT - WAS 1011181)	
120.01 · General Equipment/Tools (GENERAL EQUIPMENT - WATER - WAS ...	1,926,858.13
120.60 · Office (OFFICE EQUIPMENT - WAS 1011192)	27,331.49
120.75 · SCADA	33,384.31
120.90 · Vehicles/Generators/Trailers	901,459.76
120 · District General CRP (EQUIPMENT - WAS 1011181) - Other	95,883.57
Total 120 · District General CRP (EQUIPMENT - WAS 1011181)	2,984,917.26
122 · Bldgs/Grounds Cap Improvements	8,547,329.06
124 · D/C System Cap Improvements (COLLECTION SYSTEM - SEWER - WAS ...	
124.2 · GIS Online Mapping System	8,277.92
124.30 · Lift Stations	
124.31 · Lift Station 7 Bypass	66,042.23
124.30 · Lift Stations - Other	83,302.80
Total 124.30 · Lift Stations	149,345.03
124.50 · Mains	14,788.58
124.60 · Meters	10,000.34
124.90 · Water Tanks	40,615.04
124 · D/C System Cap Improvements (COLLECTION SYSTEM - SEWER - W...	3,146,777.14
Total 124 · D/C System Cap Improvements (COLLECTION SYSTEM - SEWER - ...	3,369,804.05
125 · Land - Dist. Cap. Improvements	299,770.00
129 · ALLOW. FOR DEPRECIATION	-10,382,491.00
Total Fixed Assets	23,282,419.97
TOTAL ASSETS	28,316,464.02
LIABILITIES & EQUITY	
Liabilities	
Current Liabilities	
Accounts Payable	
200 · ACCOUNTS PAYABLE (ACCOUNTS PAYABLE - WAS 2097200)	61,038.38
Total Accounts Payable	61,038.38
Credit Cards	
211 · WAB Credit Card	
211.13 · WAB - Jeremy - 2499	140.62
Total 211 · WAB Credit Card	140.62
Total Credit Cards	140.62
Other Current Liabilities	
800 · Bulk Water Deposit	2,000.00
Annual Depreciation	249,035.55
224 · USDA Retainage	99,265.05
223.56 · FEDERAL PAYROLL TAX PENALTY (Failure to make a federal ta...	-3,928.96
280 · Loan	
280.04 · 2021 Water Truck	64,764.11
280.15 · USDA Water Improvement Project (USDA Wtr Improvement P...	4,850,499.81
280.02 · KS State Bank - 2019 Vac-Con	122,465.89
280.12 · USDA Loan for Sewer Clarifier	2,998,172.41
Total 280 · Loan	8,035,902.22
221 · Health Ins - EE Portion	-2,742.74
222 · Direct Deposit Liabilities (Direct Deposit Liabilities)	383.04
223.15 · GARNISHMENTS (GARNISHMENT MAIN - NEW GL)	
223.17 · GARNISHMENT - LAKE CO SHERIFF (GARNISHMENT - LAKE ...	18,243.91
223.15 · GARNISHMENTS (GARNISHMENT MAIN - NEW GL) - Other	-17,377.28
Total 223.15 · GARNISHMENTS (GARNISHMENT MAIN - NEW GL)	866.63

Clearlake Oaks County Water District
Balance Sheet
As of July 31, 2023

	Jul 31, 23
223.55 · FEDERAL PAYROLL TAX WITHHOLDING (FEDERAL PAYROLL T...	-1,050.73
223.65 · STATE DISABILITY PAYABLE (STATE DISABILITY PAYABLE - W...	-1.00
223.75 · PAYROLL DEDUCTION - INS CO-PAY (PAYROLL DEDUCTION - ...	-12,264.24
223.80 · GASB 68 Pension (- WAS 2097190)	26,313.00
223.85 · MISC DEDUCTIONS PAYABLE (MISC DEDUCTIONS PAYABLE - ...	6,993.77
223.90 · COMPENSATED EMPLOYEE BENEFITS (COMPENSATED EMPL...	72,925.02
24000 · Payroll Liabilities (Unpaid payroll liabilities. Amounts withheld or...	-16,126.11
Total Other Current Liabilities	8,457,570.50
Total Current Liabilities	8,518,749.50
Long Term Liabilities	
295 · NET PWNSION LIABILITY	1,032,862.00
281 · BOND PAYABLE (GE LOAN - BOND PAYABLE 1975 WATER GEN. - W...	-371,172.41
Total Long Term Liabilities	661,689.59
Total Liabilities	9,180,439.09
Equity	
302 · RETAINED EARNINGS (RETAINED EARNINGS - WAS 3030300)	3,357,835.60
304 · Opening Balance Equity (Opening balances during setup post to this acc...	-584,283.24
306 · Retained Earnings - OLD (Undistributed earnings of the corporation - EN...	16,335,591.17
Net Income	26,881.40
Total Equity	19,136,024.93
TOTAL LIABILITIES & EQUITY	28,316,464.02

Clearlake Oaks County Water District

08/10/23

Profit and Loss

Accrual Basis

July 2023

	Admin (GL)	Sewer (GL)	Water (GL)	Total GL
Ordinary Income/Expense				
Income				
Income				
445 · Bulk Water	0.00	0.00	36,293.00	36,293.00
410 · Client Reg Pmt	0.00	89,811.88	128,149.85	217,961.73
430 · Penalty & Interest	0.00	1,694.60	2,951.98	4,646.58
450 · Other - Non S/W Rev	0.00	0.00	78.85	78.85
Total Income	<u>0.00</u>	<u>91,506.48</u>	<u>167,473.68</u>	<u>258,980.16</u>
Total Income	<u>0.00</u>	<u>91,506.48</u>	<u>167,473.68</u>	<u>258,980.16</u>
Gross Profit	<u>0.00</u>	<u>91,506.48</u>	<u>167,473.68</u>	<u>258,980.16</u>
Expense				
Salaries & EE Benefits				
505 · Salaries & Wages	42,775.25	23,287.94	17,861.28	83,924.47
520 · FICA - District Share	3,201.64	1,722.14	1,333.23	6,257.01
530 · Med/Life Insurance- Dist Share	6,026.67	6,485.16	2,538.48	15,050.31
540 · PERS - District Share	10,116.38	2,182.54	873.31	13,172.23
Total Salaries & EE Benefits	<u>62,119.94</u>	<u>33,677.78</u>	<u>22,606.30</u>	<u>118,404.02</u>
Services & Supplies				
610 · Bank Fees	3,044.42	0.00	0.00	3,044.42
620 · Communications & Internet	216.92	1,555.23	1,390.10	3,162.25
640 · Fuel & Oil	0.00	250.15	500.29	750.44
645 · Insurance	0.00	16,513.75	16,513.75	33,027.50
657 · Lab	0.00	1,335.73	1,720.00	3,055.73
660 · Memberships & Subscription	75.06	150.00	250.04	475.10
675 · Professional Services	8,649.25	1,084.91	0.00	9,734.16
685 · Rents	1,743.79	0.00	0.00	1,743.79
690 · Safety & Security	6.70	154.11	359.48	520.29
700 · Tools & Instruments	0.00	10.87	46.11	56.98
703 · Supplies - Clothing & Personal	0.00	583.63	410.18	993.81
705 · Supplies - Office	663.52	243.89	0.00	907.41
715 · Supplies-Chemicals-Operating	0.00	5,009.03	683.05	5,692.08
720 · Supplies - Inventory - Other	0.00	132.35	60.30	192.65
750 · Utilities	1,238.88	7,653.72	48,238.03	57,130.63
760 · Waste Disposal	60.06	7,234.94	3,984.91	11,279.91
798 · Customer Refund (Discrepancies ...	0.00	0.00	1,247.93	1,247.93
Total Services & Supplies	<u>15,698.60</u>	<u>41,912.31</u>	<u>75,404.17</u>	<u>133,015.08</u>
Repairs & Replacement				
810 · R&R Buildings & Grounds	0.00	541.48	0.00	541.48
Total Repairs & Replacement	<u>0.00</u>	<u>541.48</u>	<u>0.00</u>	<u>541.48</u>
Total Expense	<u>77,818.54</u>	<u>76,131.57</u>	<u>98,010.47</u>	<u>251,960.58</u>
Net Ordinary Income	<u>-77,818.54</u>	<u>15,374.91</u>	<u>69,463.21</u>	<u>7,019.58</u>
Net Income	<u>-77,818.54</u>	<u>15,374.91</u>	<u>69,463.21</u>	<u>7,019.58</u>

**CLO Water and Wastewater District
PROJECTED BUDGET 2023-2024**

1

Target % > **8%**

As of July 2023 Summary	<u>WATER</u>				<u>WASTEWATER</u>			
	Budget		Actual YTD		Budget		Actual YTD	
	Annual	YTD	Amount	%	Annual	YTD	Amount	%
Total Operating Revenue	1,336,960	111,413	167,474	13%	1,199,990	99,999	91,507	8%
Total Operating Expenses	1,316,662	109,722	135,670	10%	1,305,027	108,752	115,042	9%
Operating Balance (loss)	20,298	1,692	31,804		(105,037)	(8,753)	(23,535)	
420 Connection Fees	20,000	1,667	-	0%	20,000	1,667	-	0%
445 Bulk Water Sales	50,000		36,293					
450 Non S/W Rev - ATT Cell Lease	6,500	542	79		6,500	542		
450 Non S/W Rev - County Treasury	130,000	10,833	-	0%	130,000	10,833		0%
Reserves	150,000	12,500	-	0%	50,000	4,167		0%
Net Change In Net Position (loss)		2,233	31,804		1,463	122	(23,535)	

Current Revenue Notes:

450 - Other - Non S/W Rev: ATT Lease and Tax Roll

Past Revenue Notes

General Ledger	\$933,074.29
District CRP	\$212,460.40
Paradise Cove CRP	\$98,605.34
Water Reserve	\$174,949.73
Sewer Reserve	\$137,994.43
CalPERS Reserve	\$88,351.77
LAIF Account	\$290,488.28
Total	\$1,002,849.95

As of July 2023 Operating Revenue	<u>WATER</u>				<u>SEWER</u>			
	Budget		Actual YTD		Budget		Actual YTD	
	Annual	YTD	Amount	%	Annual	YTD	Amount	%
410 Client Reg Pmt	1,306,960	108,913	128,150	10%	1,166,990	97,249	89,812	8%
430 Penalty & Interest	30,000	2,500	2,952	10%	33,000	2,750	1,695	5%
440 Misc	-	-	-	0%	-	-	-	0%
Total Revenue >	1,336,960	111,413	131,102	10%	1,199,990	99,999	91,507	8%

As of July 2023 Operating Expenses	Budget				Actual			
	Budget		Actual		Budget		Actual	
	Annual	YTD	YTD	%	YTD	%	Spent	%
505 Salaries & Wages	442,680	36,890	39,249	9%	569,912	47,493	44,676	8%
520 FICA - District Share	36,806	3,067	2,934	8%	47,735	3,978	3,323	7%
530 Medical Ins - District Share	73,742	6,145	5,552	8%	115,507	9,626	9,499	8%
540 PERS - District Share	77,241	6,437	5,931	8%	91,971	7,664	7,241	8%
550 Unemployment	2,500	208	-	0%	2,500	208	-	0%
560 Workers Comp Ins	8,963	747	-	0%	10,284	857	-	0%
Salaries and Employee Benefits >	641,933	53,494	53,665	8%	837,908	69,826	64,738	8%
605 Advertising	200	17	-	0%	200	17	-	0%
610 Bank Fees	16,510	1,376	1,522	9%	16,500	1,375	1,522	9%
620 Communications & Internet	19,000	1,583	1,499	8%	19,000	1,583	1,664	9%
622 Board Exp	3,500	292	-	0%	3,500	292	-	0%
625 Equip - Field (\$300-\$4999)	2,500	208	-	0%	4,000	333	-	0%
630 Equip - Office	1,500	125	-	0%	2,000	167	-	0%
640 Fuel & Oil	15,200	1,267	500	3%	12,500	1,042	250	2%
645 Insurance	42,000	3,500	16,514	39%	42,000	3,500	16,514	39%

20

650	Interest	3,000	250	-	0%	3,000	250	-	0%
657	Lab	20,000	1,667	1,720	9%	13,500	1,125	1,336	10%
660	Memberships & Subscriptions	40,250	3,354	288	1%	41,250	3,438	188	0%
665	Mileage Reimb	750	63	-	0%	500	42	-	0%
670	Postage & Shipping	13,000	1,083	-	0%	13,000	1,083	-	0%
675	Professional Services	30,000	2,500	4,325	14%	25,000	2,083	5,410	22%
685	Rents	7,250	604	872	12%	7,250	604	872	12%
690	Safety & Security	5,250	438	363	7%	8,750	729	158	2%
700	Tools & Instruments	3,700	308	46	1%	2,500	208	11	0%
703	Supplies - Clothing & Personal	2,800	233	410	15%	3,100	258	584	19%
705	Supplies - Office	3,500	292	332	9%	3,500	292	576	16%
715	Treatment Chemicals	125,250	10,438	683	1%	55,000	4,583	5,009	9%
720	Supplies - Operating - Other	5,000	417	60	1%	25,000	2,083	132	1%
730	Taxes - Licenses	0	0	-	0%	0	0	-	0%
735	Training	2,250	188	-	0%	1,250	104	-	0%
745	Travel	1,000	83	-	0%	500	42	-	0%
750	Utilities	191,250	15,938	48,858	26%	108,250	9,021	8,274	8%
760	Waste Disposal	48,319	4,027	4,015	8%	48,319	4,027	7,265	15%
795	Yolo Co	61,000	5,083	-	0%				
799	Misc	1,750	146	-	0%	1,750	146	-	0%
Services and Supplies >		665,729	55,477	82,005	12%	461,119	38,427	49,763	11%
810	R&R Buildings & Grounds	6,000	500	-	0%	3,500	292	541	15%
815	R & R Damage Claims	0	0	-	0%	-	-	-	0%
820	R&R Lift Stations	-	-	-	0%	-	-	-	0%
830	R&R Equipment	0	0	-	0%	0	0	-	0%
832	R&R Mains/Service Lines	-	-	-	0%	-	-	-	0%
840	R&R Vehicles (\$2k/vehicle)	3,000	250	-	0%	2,500	208	-	0%
850	Maintenance Reserve Account	-	-	-		-	-	-	
Repairs & Replacement >		9,000	750	-	0%	6,000	500	541	9%
Total Expenses >		1,316,662	109,722	135,670	10%	1,305,027	108,752	115,042	9%

1 Administration Budget Variance Report July 1, 2023 through June 30, 2024		Target % >		8.3%	GL ADMIN	
As of July 2023		2023-2024 Budget		Actual	%	
Expenses		Annual	YTD	YTD	Spent	Total Remaining
505	Salaries & Wages	482,771	40,231	42,775	8.9%	439,996
520	FICA - District Share	40,446	3,371	3,202	7.9%	37,244
530	Medical Ins - District Share	79,552	6,629	6,027	7.6%	73,525
540	PERS-District Share (incl unfunded Liab, 78,867.)	129,630	10,802	10,116	7.8%	119,514
550	Unemployment	5,000	417		0.0%	5,000
560	Workers Comp Ins	3,348	279		0.0%	3,348
Salaries and Employee Benefits >		740,746	61,729	62,120	8.4%	678,626
605	Advertising	400	33	-	0.0%	400
610	Bank Fees	33,000	2,750	3,044	9.2%	29,956
620	Communications & Internet	7,000	583	217	3.1%	6,783
622	Board Exp	7,000	583		0.0%	7,000
625	Equip - Field (up to \$4999)	0	0		0.0%	0
630	Equip - Office	2,000	167		0.0%	2,000
640	Fuel & Oil	0	0		0.0%	0
645	Insurance	0	0		0.0%	0
650	Interest	0	0		0.0%	0
657	Outsource Lab / Internal Lab	0	0		0.0%	0
660	Memberships & Subscriptions	4,500	375	75	1.7%	4,425
665	Mileage Reimb	500	42		0.0%	500
670	Postage & Shipping	26,000	2,167		0.0%	26,000
675	Professional Services (Legal, IT, CUSI annual)	40,000	3,333	8,649	21.6%	31,351
685	Rents	14,500	1,208	1,744	12.0%	12,756
690	Safety & Security (boots)	1,500	125	7	0.5%	1,493
700	Tools & Instruments	0	0		0.0%	0
703	Supplies - Clothing & Personal	600	50		0.0%	600
705	Supplies - Office	5,000	417	664	13.3%	4,336
715	Treatment Chemicals	0	0		0.0%	0
720	Supplies - Operating - Other	0	0		0.0%	0
730	Taxes - Licenses	0	0		0.0%	0
735	Training, Certs (Classes, books)	500	42		0.0%	500
745	Travel / Lodging	1,000	83		0.0%	1,000
750	Utilities	6,500	542	1,239	19.1%	5,261
760	Waste Disposal	638	53	60	9.4%	578
795	Yolo Co	0	0		0.0%	0
798	Customer Refund					
799	Team Building	3,500	292		0.0%	3,500
Services and Supplies >		154,138	12,845	15,699	10.2%	138,439
810	R&R Buildings & Grounds	2,000	167		0.0%	2,000
815	R & R Damage Claims	0	0		0.0%	0
820	R&R Lift Stations	-	-		0.0%	-
830	R&R Equipment	0	0		0.0%	0
832	R&R Mains/Service Lines	0	0		0.0%	0
840	R&R Vehicles (\$2k/vehicle)	0	0		0.0%	0
Repairs & Replacement >		2,000	167	-	0.0%	2,000
Total Expenses >		896,884	74,740	77,819	8.7%	819,065

1 Wastewater Budget Variance Report July 1, 2023 through June 30, 2024		Target % >		8.3%	GL WASTEWATER
As of July 2023		2023-2024 Budget		Actual	%
Expenses	Annual	YTD	YTD	Spent	Total Remaining
505 Salaries & Wages	328,526	27,377	23,288	7.1%	305,238
520 FICA - District Share	27,512	2,293	1,722	6.3%	25,790
530 Medical Ins - District Share	75,731	6,311	6,485	8.6%	69,246
540 PERS - District Share (\$14.5K Unfunded)	27,156	2,263	2,183	8.0%	24,973
550 Unemployment	0	0		0.0%	0
560 Workers Comp Ins	8,610	718		0.0%	8,610
Salaries and Employee Benefits >	467,535	38,961	33,678	7.2%	433,857
605 Advertising	0	0		0.0%	0
610 Bank Fees	0	0		0.0%	0
620 Communications & Internet	13,000	1,083	1,555	12.0%	11,445
622 Board Exp	0	0		0.0%	0
625 Equip - Field (up to \$4999)	1,500	125		0.0%	1,500
630 Equip - Office	1,000	83		0.0%	1,000
640 Fuel & Oil (Schaeffers)	7,500	625	250	3.3%	7,250
645 Insurance	42,000	3,500	16,514	39.3%	25,486
650 Interest	0	0		0.0%	0
657 Outsource Lab / Internal Lab	13,500	1,125	1,336	9.9%	12,164
660 Memberships/Subscriptions/Permits	39,000	3,250	150	0.4%	38,850
665 Mileage Reimb	250	21		0.0%	250
670 Postage & Shipping	0	0		0.0%	0
675 Professional Services (SCADA)	5,000	417	1,085	21.7%	3,915
685 Rents	0	0		0.0%	0
690 Safety & Security (includes boots)	8,000	667	154	1.9%	7,846
700 Tools & Instruments	2,500	208	11	0.4%	2,489
703 Supplies - Clothing & Personal	2,800	233	584	20.9%	2,216
705 Supplies - Office	1,000	83	244	24.4%	756
715 Treatment Chemicals	55,000	4,583	5,009	9.1%	49,991
720 Supplies-Operating-Other-Titan Tubes	25,000	2,083	132	0.5%	24,868
730 Taxes - Licenses	-	-			-
735 Training, Certs (classes, books)	1,000	83		0.0%	1,000
745 Travel / Lodging	-	-		0.0%	-
750 Utilities	105,000	8,750	7,654	7.3%	97,346
760 Waste Disposal	48,000	4,000	7,235	15.1%	40,765
795 Yolo Co	0	0		0.0%	0
798 Customer Refund					
799 Misc	0	0		0.0%	0
799.1 Team Building					
Services and Supplies >	371,050	30,921	41,913	11.3%	329,137
810 R&R Buildings & Grounds	2,500	208	541	21.6%	1,959
815 R & R Damage Claims	0	0		0.0%	0
820 R&R Lift Stations	0	0		0.0%	0
830 R&R Equipment	0	0		0.0%	0
832 R&R Mains/Service Lines	0	0	-	0.0%	-
840 R&R Vehicles	2,500	208		0.0%	2,500
	-	-		0.0%	-
Repairs & Replacement >	5,000	417	541	10.8%	4,459
Total Expenses >	843,585	70,299	76,132	9.0%	767,453
Expense Notes					

1	Water Budget Variance Report July 1, 2023 through June 30, 2024 As of July 2023	2023-2024 Budget		Target % >	8.3%	GL WATER
	Expenses	Annual	YTD	Actual YTD	% Spent	Total Remaining
505	Salaries & Wages	201,295	16,775	17,861	8.9%	183,434
520	FICA - District Share	16,583	1,382	1,333	8.0%	15,250
530	Medical Ins - District Share	33,966	2,831	2,538	7.5%	31,428
540	PERS - District Share	12,426	1,035	873	7.0%	11,553
550	Unemployment	0	0		0.0%	0
560	Workers Comp Ins	7,289	607		0.0%	7,289
	Salaries and Employee Benefits >	271,560	22,630	22,605	8.3%	248,955
605	Advertising	0	0		0.0%	0
610	Bank Fees	0	0		0.0%	0
620	Communications & Internet	13,000	1,083	1,390	10.7%	11,610
622	Board Exp	0	0		0.0%	0
625	Equip - Field (\$300 - \$4999)	0	0		0.0%	0
630	Equip - Office	500	42		0.0%	500
640	Fuel & Oil	10,200	850	500	4.9%	9,700
645	Insurance	42,000	3,500	16,514	39.3%	25,486
650	Interest	0	0		0.0%	0
657	Outside Lab / Internal Lab	20,000	1,667	1,720	8.6%	18,280
660	Memberships/Subscriptions/Permits	38,000	3,167	250	0.7%	37,750
665	Mileage Reimb	500	42		0.0%	500
670	Postage & Shipping	0	0		0.0%	0
675	Professional Services (SCADA, Mtce Prog)	10,000	833		0.0%	10,000
685	Rents	0	0		0.0%	0
690	Safety & Security (includes boots)	4,500	375	359	8.0%	4,141
700	Tools & Instruments	3,700	308	46	1.2%	3,654
703	Supplies - Clothing & Personal	2,500	208	410	16.4%	2,090
705	Supplies - Office	1,000	83		0.0%	1,000
715	Treatment Chemicals	125,250	10,438	683	0.5%	124,567
720	Supplies - Operating - Other	5,000	417	60	1.2%	4,940
730	Taxes - Licenses	0	0		0.0%	0
735	Training, Certs (classes, books)	2,000	167		0.0%	2,000
745	Travel / Lodging	500	42		0.0%	500
750	Utilities	188,000	15,667	48,238	25.7%	139,762
760	Waste Disposal	48,000	4,000	3,985	8.3%	44,015
795	Yolo Co	61,000	5,083		0.0%	61,000
798	Customer Refund			1,248		
799	Team Building	0	0		0.0%	0
799.1	Customer Refund					
	Services and Supplies >	575,650	47,971	75,403	13.1%	500,247
810	R&R Buildings & Grounds	5,000	417		0.0%	5,000
815	R & R Damage Claims	0	0		0.0%	0
820	R&R Lift Stations	0	0		0.0%	0
830	R&R Equipment	0	0		0.0%	0
832	R&R Mains	0	0		0.0%	-
840	R&R Vehicles	3,000	250		0.0%	3,000
	Repairs & Replacement >	8,000	667	-	0.0%	8,000
	Total Expenses >	855,210	71,267	98,008	11.5%	757,202

Clearlake Oaks County Water District

CRP/CIP Profit and Loss

July 2023

	PC (CRP)	Water (CRP)	Sewer (CRP)	Total CRP	TOTAL
Ordinary Income/Expense					
Income					
Income					
425 · CRP (Capital Repl...	1,686.40	37,052.60	41,876.03	80,615.03	80,615.03
430 · Penalty & Interest	21.76	850.89	864.57	1,737.22	1,737.22
Total Income	<u>1,708.16</u>	<u>37,903.49</u>	<u>42,740.60</u>	<u>82,352.25</u>	<u>82,352.25</u>
Total Income	<u>1,708.16</u>	<u>37,903.49</u>	<u>42,740.60</u>	<u>82,352.25</u>	<u>82,352.25</u>
Gross Profit	<u>1,708.16</u>	<u>37,903.49</u>	<u>42,740.60</u>	<u>82,352.25</u>	<u>82,352.25</u>
Expense					
Salaries & EE Benefits					
505 · Salaries & Wages	0.00	16,106.23	15,478.15	31,584.38	31,584.38
520 · FICA - District Sh...	0.00	1,194.44	1,129.93	2,324.37	2,324.37
530 · Med/Life Insuran...	0.00	2,135.74	3,890.73	6,026.47	6,026.47
540 · PERS - District S...	0.00	947.73	967.38	1,915.11	1,915.11
Total Salaries & EE Benef...	<u>0.00</u>	<u>20,384.14</u>	<u>21,466.19</u>	<u>41,850.33</u>	<u>41,850.33</u>
Services & Supplies					
640 · Fuel & Oil	0.00	625.35	625.35	1,250.70	1,250.70
650 · Interest	0.00	292.70	292.69	585.39	585.39
Total Services & Supplies	<u>0.00</u>	<u>918.05</u>	<u>918.04</u>	<u>1,836.09</u>	<u>1,836.09</u>
Repairs & Replacement					
810 · R&R Buildings & ...	0.00	23.91	0.00	23.91	23.91
830 · R&R Equipment	0.00	0.00	95.42	95.42	95.42
832 · R&R Mains and S...	0.00	182.87	182.86	365.73	365.73
840 · R&R Vehicles	0.00	7,463.46	6,698.51	14,161.97	14,161.97
Total Repairs & Replacem...	<u>0.00</u>	<u>7,670.24</u>	<u>6,976.79</u>	<u>14,647.03</u>	<u>14,647.03</u>
Total Expense	<u>0.00</u>	<u>28,972.43</u>	<u>29,361.02</u>	<u>58,333.45</u>	<u>58,333.45</u>
Net Ordinary Income	<u>1,708.16</u>	<u>8,931.06</u>	<u>13,379.58</u>	<u>24,018.80</u>	<u>24,018.80</u>
Net Income	<u>1,708.16</u>	<u>8,931.06</u>	<u>13,379.58</u>	<u>24,018.80</u>	<u>24,018.80</u>

Clearlake Oaks Co Water District
Budget Variance Report July 1, 2023 through June 30, 2024

Target % > **8.3%** **CRP-PC**

1

As of July 2023

Summary	Budget Annual	YTD	Actual YTD Amount	%		
PC CRP Revenue	19,536	1,628	1,708	8.7%		
PC CRP Expenses	0	0	-	0.0%		
		2023-2024 Budget	Actual	%	Total	
Expenses	Annual	YTD	YTD	Spent	Remaining	
605 Advertising	-	-	-	0.0%	-	
610 Bank Fees	-	-	-	0.0%	-	
620 Communications & Internet	-	-	-	0.0%	-	
622 Board Exp	-	-	-	0.0%	-	
625 Equip - Field (up to \$4999)	-	-	-	0.0%	-	
630 Equip - Office	-	-	-	0.0%	-	
640 Fuel & Oil	-	-	-	0.0%	-	
645 Insurance	-	-	-	0.0%	-	
650 Interest	-	-	-	0.0%	-	
657 Outsource Lab / Internal Lab	-	-	-	0.0%	-	
660 Memberships & Subscriptions	-	-	-	0.0%	-	
665 Mileage Reimb	-	-	-	0.0%	-	
670 Postage & Shipping	-	-	-	0.0%	-	
675 Professional Services (SCADA)	-	-	-	0.0%	-	
685 Rents	-	-	-	0.0%	-	
690 Safety & Security (includes boots	-	-	-	0.0%	-	
700 Tools & Instruments	-	-	-	0.0%	-	
703 Supplies - Clothing & Personal	-	-	-	0.0%	-	
705 Supplies - Office	-	-	-	0.0%	-	
715 Treatment Chemicals	-	-	-	0.0%	-	
720 Supplies - Operating - Other	-	-	-	0.0%	-	
730 Taxes - Licenses	-	-	-	0.0%	-	
735 Training, Certs (classes, books)	-	-	-	0.0%	-	
745 Travel / Lodging	-	-	-	0.0%	-	
750 Utilities	-	-	-	0.0%	-	
760 Waste Disposal	-	-	-	0.0%	-	
795 Yolo Co	-	-	-	0.0%	-	
799 Team Building	0	0	-	0.0%	0	
Services and Supplies >		0	0	-	0.0%	0
810 R&R Buildings & Grounds	-	-	-	0.0%	-	
815 R & R Damage Claims	0	0	-	0.0%	0	
820 R&R Lift Stations	-	-	-	0.0%	-	
830 R&R Equipment	-	-	-	0.0%	-	
832 R&R Mains/Laterals	-	-	-	0.0%	-	
840 R&R Vehicles	-	-	-	0.0%	-	
Repairs & Replacement >		0	0	-	0.0%	0
Total Expenses >		0	0	-	0.0%	0

Budget Variance Report July 1, 2023 through June 30, 2024

Target % > **8.3%** **CRP-WATER**

As of July 2023 Summary		WATER - CRP Budget			Actual YTD		
		Annual	YTD		Amount	%	
WATER CRP Revenue		461,460	38,455	37,903	8.2%	0%	
WATER CRP Expenses		411,094	34,258		0.0%	0%	
Operating Balance		50,366	4,197	37,903			
Expenses		2020-2021 Annual	Budget YTD	Actual YTD	% Spent	Total Remaining	
505	Salaries & Wages	204,827	17,069	16,106	7.9%	188,721	
520	FICA - District Share	17,051	1,421	1,194	7.0%	15,857	
530	Medical Ins - District Share	28,192	2,349	2,136	7.6%	26,056	
540	PERS - District Share	13,350	1,112	948	7.1%	12,402	
550	Unemployment	0	0		0.0%	0	
560	Workers Comp Ins	6,525	544		0.0%	6,525	
Salaries and Employee Benefits >		269,944	22,495	20,384	7.6%	249,560	
605	Advertising	0	0	-	0.0%	0	
610	Bank Fees	0	0	-	0.0%	0	
620	Communications & Internet	3,500	292		0.0%	3,500	
622	Board Exp	0	0		0.0%	0	
625	Equip - Field (up to \$4999)	1,250	104		0.0%	1,250	
630	Equip - Office	-					
640	Fuel & Oil	14,400	1,200	625	4.3%	13,775	
645	Insurance	0	0		0.0%	0	
650	Interest	6,000	500	293	0.0%	5,707	
657	Outsource Lab / Internal Lab	3,000	250		0.0%	3,000	
660	Memberships & Subscriptions	0	0		0.0%	0	
665	Mileage Reimb	0	0		0.0%	0	
670	Postage & Shipping	0	0		0.0%	0	
675	Professional Services Leak Chk	-	-		0.0%	-	
685	Rents	0	0		0.0%	0	
690	Safety & Sec (includes boots)	-	-		0.0%	-	
700	Tools & Instruments	2,000	167		0.0%	2,000	
703	Supplies - Clothing & Personal	1,500	125		0.0%	1,500	
705	Supplies - Office	-	-		0.0%	-	
715	Treatment Chemicals	0	0		0.0%	0	
720	Supplies - Operating - Other	3,000	250		0.0%	3,000	
730	Taxes - Licenses	0	0		0.0%	0	
735	Training, Certs (classes, books)	500	42		0.0%	500	
745	Travel / Lodging	-	-		0.0%	-	
750	Utilities	0	0		0.0%	0	
760	Waste Disposal	0	0		0.0%	0	
795	Yolo Co	0	0		0.0%	0	
799	Team Building	0	0		0.0%	0	
Services and Supplies >		35,150	2,929	918	2.6%	34,232	
810	R&R Buildings & Grounds	3,000	250	24	0.8%	2,976	
815	R & R Damage Claims	0	0		0.0%	0	
820	R&R Lift Stations	0	0		0.0%	0	
830	R&R Equipment	35,000	2,917		0.0%	35,000	
830.1	Hydrants	-					
832	R&R Mains/Service Lines/Tanks	50,000	4,167	183	0.4%	49,817	
840	R&R Vehicles	18,000	1,500	7,463	41.5%	10,537	
840: Repr of Dump Tr		Repairs & Replacement >	106,000	8,833	7,670	7.2%	98,330
		Total Expenses >	411,094	34,258	28,972	7.0%	382,122

**Clearlake Oaks County Water District
 Capital Improvements
 As of July 31, 2023**

Date	Name	Memo	Class	Amount
	130 · Const In Progress - Studies			
	135 · CRP WATER (CAPITOL IMPROVEMENTS - WATER - WAS 1199100)			
	138 · USDA Water Improvements			
07/06/2023	MC Engineering, Inc	USDA Water Improv	Loan/Grant:...	2,106.27
07/12/2023		Deposit	Loan/Grant:...	-14,632.70
	Total 138 · USDA Water Improvements			-12,526.43
	128 · Sewer Infrstrcture & Rehab Proj (Phase 1 was the installation of the Force Main)			
	Total 128 · Sewer Infrstrcture & Rehab Proj (Phase 1 was the installation of the F...			
	121 · Wtr Dist & Wtr Storage Projects (Replacement or installation of water distrib...			
	131 · Waste Water Plant			
	131.1 · Pumps/Equipment			
	Total 131.1 · Pumps/Equipment			
	131 · Waste Water Plant - Other			
	Total 131 · Waste Water Plant - Other			
	Total 131 · Waste Water Plant			
	127 · Water Plant			
	127.7 · Ozone System			
	Total 127.7 · Ozone System			
	127.6 · Swan AMI Turbiwell Monitor			
	Total 127.6 · Swan AMI Turbiwell Monitor			
	127.5 · A/C installation for Filter Rm			
	Total 127.5 · A/C installation for Filter Rm			
	127.4 · PH System			
	Total 127.4 · PH System			
	127.2 · Harvy Vault Chlor Inject Proj			
	Total 127.2 · Harvy Vault Chlor Inject Proj			
	127.1 · Major Equipment			
	Total 127.1 · Major Equipment			
	127 · Water Plant - Other			
	Total 127 · Water Plant - Other			
	Total 127 · Water Plant			
	120 · District General CRP (EQUIPMENT - WAS 1011181)			
	120.01 · General Equipment/Tools (GENERAL EQUIPMENT - WATER - WAS 1011190)			
	Total 120.01 · General Equipment/Tools (GENERAL EQUIPMENT - WATER - ...			
	120.60 · Office (OFFICE EQUIPMENT - WAS 1011192)			
	Total 120.60 · Office (OFFICE EQUIPMENT - WAS 1011192)			
	120.75 · SCADA			
07/12/2023	Southport Control Sol...	Programming to add...	CRP:Water	740.00
07/12/2023	Southport Control Sol...	Service call 7/6/2023...	CRP:Sewer	2,167.00
	Total 120.75 · SCADA			2,907.00
	120.90 · Vehicles/Generators/Trailers			
	Total 120.90 · Vehicles/Generators/Trailers			
	120 · District General CRP (EQUIPMENT - WAS 1011181) - Other			
	Total 120 · District General CRP (EQUIPMENT - WAS 1011181) - Other			
	Total 120 · District General CRP (EQUIPMENT - WAS 1011181)			2,907.00
	122 · Bldgs/Grounds Cap Improvements			
	Total 122 · Bldgs/Grounds Cap Improvements			
	124 · D/C System Cap Improvements (COLLECTION SYSTEM - SEWER - WAS 1011161)			
	124.2 · GIS Online Mapping System			
	Total 124.2 · GIS Online Mapping System			

Clearlake Oaks County Water District
Capital Improvements
 As of July 31, 2023

Date	Name	Memo	Class	Amount
124.30 · Lift Stations				
124.50 · Mains				
Total 124.50 · Mains				
124.60 · Meters				
Total 124.60 · Meters				
124.90 · Water Tanks				
Total 124.90 · Water Tanks				
124 · D/C System Cap Improvements (COLLECTION SYSTEM - SEWER - WAS 1011161) - Other				
Total 124 · D/C System Cap Improvements (COLLECTION SYSTEM - SEWE...				
Total 124 · D/C System Cap Improvements (COLLECTION SYSTEM - SEWER - ...				
125 · Land - Dist. Cap. Improvements				
Total 125 · Land - Dist. Cap. Improvements				
129 · ALLOW. FOR DEPRECIATION				
Total 129 · ALLOW. FOR DEPRECIATION				
280 · Loan				
280.04 · 2021 Water Truck				
07/15/2023	Kansas State Bank - ...	Payment #20	CRP:Water	756.35
07/15/2023	Kansas State Bank - ...	3359488	CRP:Sewer	756.35
Total 280.04 · 2021 Water Truck				1,512.70
280.15 · USDA Water Improvement Project (USDA Wtr Improvement Proj total \$5 Million)				
Total 280.15 · USDA Water Improvement Project (USDA Wtr Improvement Pr...				
280.02 · KS State Bank - 2019 Vac-Con				
07/15/2023	Kansas State Bank - ...	Pymt #43	CRP:Water	3,526.82
07/15/2023	Kansas State Bank - ...	3343293	CRP:Sewer	3,526.81
Total 280.02 · KS State Bank - 2019 Vac-Con				7,053.63
Total 280 · Loan				8,566.33
306 · Retained Earnings - OLD (Undistributed earnings of the corporation - ENDS 06/31/2011)				
Total 306 · Retained Earnings - OLD (Undistributed earnings of the corporation - ...				
Loans/Grants				
945 · Wastewater I and I Phase IV				
07/15/2023	AES - Analytical Envir...	WWTP Phase 4	Loan/Grant:...	344.00
Total 945 · Wastewater I and I Phase IV				344.00
940 · TA Grant				
07/06/2023	MC Engineering, Inc	SWRCB TA Grant	Loan/Grant:...	1,577.50
Total 940 · TA Grant				1,577.50
Total Loans/Grants				1,921.50
TOTAL				868.40



Accounts

[Transfer](#) [Settings](#)

CRP PC *6192

Available	**\$98,605.34
Current	\$98,605.34

CRP SEWER *3745

Available	**\$119,601.32
Current	\$119,601.32

GENERAL LEDGER *9122

Available	**\$930,375.92
Current	\$920,212.09

PUBLIC REGULAR CHK *8503

Available	**\$174,949.73
Current	\$174,949.73

PUBLIC REGULAR CHK *9592

Available	**\$137,994.43
Current	\$137,994.43

PUBLIC REGULAR CHK *7355

Available	**\$88,351.17
-----------	---------------

Make a Payment

Make paying bills fast and easy
Pay your bills on one screen in seconds.

[Sign up for payments](#)

Get Help with Taxes



We've teamed up with TurboTax to help you get your **maximum refund, guaranteed.**

[Start for free](#)

Money Management

Current \$88,351.17

CRP WATER *6990

Available **\$92,859.08

Current \$92,859.08

BALANCE TOTALS

Total Deposit Accounts \$1,632,573.16

**This balance may include overdraft or line of credit funds

Budgets made easy!



Every transaction is automatically categorized and put into a budget to help you stay on track.

[Start now](#)

Outside Accounts



No outside accounts added.

[Add account](#)

Banking on the Go with Mobile Banking

Our mobile banking app is the convenient way to access your account at any time from any mobile device. Enjoy peace of mind knowing your finances are just a click away. Simply use the same login and password you use for your desktop account and start enjoying the freedom of mobile banking.

Enjoy the convenience of Banking on the Go and download the app today!

August 2023						
Su	Mo	Tu	We	Th	Fr	Sa
30	31	1	2	3	4	5

32

California State Treasurer Fiona Ma, CPA



Local Agency Investment Fund
P.O. Box 942809
Sacramento, CA 94209-0001
(916) 653-3001

August 14, 2023

[LAIF Home](#)
[PMIA Average Monthly Yields](#)

CLEARLAKE OAKS COUNTY WATER DISTRICT

AUDITOR/SECRETARY
P.O. BOX 709
12952 HIGHWAY 20
CLEARLAKE OAKS, CA 95423-0709

[Tran Type Definitions](#)

//

Account Number: 90-17-001

July 2023 Statement

Effective Date	Transaction Date	Tran Type	Confirm Number	Web Confirm Number	Authorized Caller	Amount
7/14/2023	7/19/2023	QRD	1735595	N/A	SYSTEM	8,495.16

Account Summary

Total Deposit:	8,495.16	Beginning Balance:	1,081,993.12
Total Withdrawal:	0.00	Ending Balance:	1,090,488.28

Clearlake Oaks County Water District

Payroll Summary

July 2023

	Hours	Rate	Jul 23
Employee Wages, Taxes and Adjustments			
Gross Pay			
CTO Saved	-30.25	67.05	-1,894.04
CTO Used	97.31	35.96	4,291.88
Holiday	145.25	30.89	5,321.64
Holiday Worked (x2.5)	8.75	111.75	937.56
Overtime (x1.5)	105.5	67.05	5,773.23
PTO	341	43.73	14,778.41
Straight Board	2,105.75	30.89	80,740.17
Duty Pay			5,160.00
Total Gross Pay	2,773.31		115,508.85
Deductions from Gross Pay			
ACWA (pre-tax)			-2,786.59
AFLAC (pre-tax)			-547.38
AFLAC (taxable) AFTER TAX			-154.08
CALPers 457			-625.00
CALPers EE (Pretax)			-6,358.97
Total Deductions from Gross Pay			-10,472.02
Adjusted Gross Pay	2,773.31		105,036.83
Taxes Withheld			
Federal Withholding			-8,633.00
Medicare Employee			-1,626.53
Social Security Employee			-6,954.85
CA - Withholding			-3,568.82
CA - Disability			-1,009.59
Total Taxes Withheld			-21,792.79
Deductions from Net Pay			
Miscellaneous Deduction			-352.05
Wage Garnishment			-530.76
Total Deductions from Net Pay			-882.81
Net Pay	2,773.31		82,361.23
Employer Taxes and Contributions			
Medicare Company			1,626.53
Social Security Company			6,954.85
Total Employer Taxes and Contributions			8,581.38

Clearlake Oaks County Water District

Trial Balance

As of July 31, 2023

	Jul 31, 23	
	Debit	Credit
102.14 · CalPERS RESERVE - 7355	88,351.17	
102.13 · SEWER RESERVES-9592	137,994.43	
102.11 · PC ESCROW - 6184	0.00	
102.10 · CRP PC - 6192	98,605.34	
102.12 · WATER RESERVES- 8503	174,949.73	
102.001 · GL - 9122	92,280.51	
102.04 · DWR - CHECKING	0.00	
101 · LAIF - CASH IN BANK	892,993.12	
101 · LAIF - CASH IN BANK:CIP Deposits 2014	189,000.00	
102.01 · WEST AMERICA - REGULAR CHECKING	88.98	
102.02 · CRP Water - 6990	92,859.08	
102.03 · CRP Sewer - 3745	119,601.32	
CUSI Accounts Receivable	204,087.00	
139 · Docufree	28,727.90	
116 · DEFERRED OUTFLOW- PENSION	282,829.00	
103 · PETTY CASH	306.59	
104 · COUNTY TREASURY	26,664.68	
130 · Const In Progress - Studies	688,182.94	
130 · Const In Progress - Studies:130.97 · Const in Prog...	3,280.00	
130 · Const In Progress - Studies:130.96 · Const in Prog...	4,670.00	
130 · Const In Progress - Studies:130.95 · Source Capa...	9,859.00	
130 · Const In Progress - Studies:130.75 · SCADA	0.00	
132 · CRP SEWER	983,511.67	
132 · CRP SEWER:132.05 · CIP SEWER LABOR	0.00	
135 · CRP WATER	249,148.33	
135 · CRP WATER:135.02 · Aircon Project	0.00	
135 · CRP WATER:135.05 · Backwash Pump Filters #2-#3	0.00	
135 · CRP WATER:135.10 · High Valley Project 2013	0.00	
135 · CRP WATER:135.20 · CIP WATER LABOR	0.00	
111 · INVENTORY - WATER	0.00	
114 · ACCOUNTS RECEIVABLE.	650,661.26	
115 · PRE-PAID INSURANCE	15,392.00	
1890 · ACCOUNTS RECEIVABLE - OTHER	0.00	
12000 · Undeposited Funds	0.00	
136 · CUSI Software	13,172.00	
138 · USDA Water Improvements	8,199,063.97	
128 · Sewer Infrstructure & Rehab Proj	3,890,219.87	
121 · Wtr Dist & Wtr Storage Projects	277,266.74	
121 · Wtr Dist & Wtr Storage Projects:121.1 · Sidewalk P...	115,500.66	
131 · Waste Water Plant	230,059.50	
131 · Waste Water Plant:131.1 · Pumps/Equipment	143,307.20	
126 · Forcemain (phase 1) Cap. Imprv.	1,233,797.22	
123 · USDA - Sewer Plant Cap Imprvmt	4,265,559.43	
USDA Project		523,819.00
127 · Water Plant	211,458.66	
127 · Water Plant:127.7 · Ozone System	12,785.71	
127 · Water Plant:127.6 · Swan AMI Turbiwell Monitor	25,079.10	
127 · Water Plant:127.5 · A/C installation for Filter Rm	750.00	
127 · Water Plant:127.4 · PH System	9,959.72	
127 · Water Plant:127.2 · Harvy Vault Chlor Inject Proj	1,408.61	
127 · Water Plant:127.1 · Major Equipment	357,521.21	
120 · District General CRP	95,883.57	
120 · District General CRP:120.01 · General Equipment/...	1,926,858.13	
120 · District General CRP:120.60 · Office	27,331.49	
120 · District General CRP:120.75 · SCADA	33,384.31	
120 · District General CRP:120.90 · Vehicles/Generators/...	901,459.76	
122 · Bldgs/Grounds Cap Improvements	8,547,329.06	
124 · D/C System Cap Improvements	3,146,777.14	
124 · D/C System Cap Improvements:124.2 · GIS Online ...	8,277.92	
124 · D/C System Cap Improvements:124.30 · Lift Stations	83,302.80	
124 · D/C System Cap Improvements:124.30 · Lift Statio...	66,042.23	
124 · D/C System Cap Improvements:124.50 · Mains	14,788.58	
124 · D/C System Cap Improvements:124.60 · Meters	10,000.34	
124 · D/C System Cap Improvements:124.90 · Water Tan...	40,615.04	
125 · Land - Dist. Cap. Improvements	299,770.00	
129 · ALLOW. FOR DEPRECIATION		10,382,491.00
200 · ACCOUNTS PAYABLE		61,038.38
211 · WAB Credit Card:211.17 · WAB - Kurt - 0390	0.00	

Clearlake Oaks County Water District

Trial Balance

As of July 31, 2023

	Jul 31, 23	
	Debit	Credit
211 · WAB Credit Card:211.16 · WAB - Francisco - 5312	0.00	
211 · WAB Credit Card:211.15 · WAB - Kurt - 9133	0.00	
211 · WAB Credit Card:211.14 · WAB - Dianna - 3226	0.00	
211 · WAB Credit Card:211.13 · WAB - Jeremy - 2499		140.62
211 · WAB Credit Card:211.12 · WAB- Francisco - 2481	0.00	
211 · WAB Credit Card:211.11 · WAB - Dan - 2507	0.00	
211 · WAB Credit Card:211.10 · WAB - Dianna - 2473	0.00	
210 · Cal Card	0.00	
210 · Cal Card:210-09 · Cal Card - 5855	0.00	
210 · Cal Card:210-08 · Cal Card - 5848	0.00	
210 · Cal Card:210-07 · Cal-Card	0.00	
210 · Cal Card:210.06 - Cal Card - 3879	0.00	
210 · Cal Card:210.05 · Cal Card - 4075	0.00	
210 · Cal Card:210.04 · Cal Card - 7397	0.00	
210 · Cal Card:210.01 · Cal Card -	0.00	
210 · Cal Card:210.02 · Cal Card 0010	0.00	
210 · Cal Card:210.03 · Cal Card	0.00	
800 · Bulk Water Deposit		2,000.00
Annual Depreciation		249,035.55
224 · USDA Retainage		99,265.05
223.56 · FEDERAL PAYROLL TAX PENALTY	3,928.96	
280 · Loan:280.04 · 2021 Water Truck		64,764.11
280 · Loan:280.15 · USDA Water Improvement Project		4,850,499.81
280 · Loan:280.02 · KS State Bank - 2019 Vac-Con		122,465.89
280 · Loan:280.12 · USDA Loan for Sewer Clarifier		2,998,172.41
280 · Loan:280.10 · Bridge for I & I Rehab Project	0.00	
280 · Loan:280.07 · Bridge Loan for Forced Main	0.00	
280 · Loan:280.05 · USDA Bridge Loan	0.00	
280 · Loan:280.01 · Kansas State Bk - VACON	0.00	
280 · Loan:280.03 · Kansas State Bk - Camera Traile	0.00	
220 · Restricted - Expansion Fee's	0.00	
221 · Health Ins - EE Portion	2,742.74	
221 · Health Ins - EE Portion:221.1 · EE Cobra Payments...	0.00	
222 · Direct Deposit Liabilities		383.04
223 · COMP DUMP ACCOUNT	0.00	
223 · COMP DUMP ACCOUNT:223.01 · ADMIN - COMP U...	0.00	
223 · COMP DUMP ACCOUNT:223.02 · SEWER - COMP ...	0.00	
223 · COMP DUMP ACCOUNT:223.03 · WATER - COMP ...	0.00	
223.15 · GARNISHMENTS	17,377.28	
223.15 · GARNISHMENTS:223.16 · GARNISHMENT - CO...	0.00	
223.15 · GARNISHMENTS:223.17 · GARNISHMENT - LAK...		18,243.91
223.20 · STATE UNEMPLOYMENT TAX PAYABLE	0.00	
223.25 · Vacation Dump Account	0.00	
223.25 · Vacation Dump Account:223.26 · Admin - Vacat...	0.00	
223.25 · Vacation Dump Account:223.27 · Sewer - Vacati...	0.00	
223.25 · Vacation Dump Account:223.28 · Water - Vacati...	0.00	
223.30 · Sick Dump Account	0.00	
223.30 · Sick Dump Account:223.31 · Admin - Sick	0.00	
223.30 · Sick Dump Account:223.32 · Sewer - Sick	0.00	
223.30 · Sick Dump Account:223.33 · Water - Sick	0.00	
223.40 · ACCRUED PAYROLL	0.00	
223.45 · FICA & SOCIAL SEC PAYABLE	0.00	
223.50 · MEDICARE TAX PAYABLE	0.00	
223.55 · FEDERAL PAYROLL TAX WITHHOLDING	1,050.73	
223.60 · STATE PAYROLL TAX WITHHOLDING	0.00	
223.65 · STATE DISABILITY PAYABLE	1.00	
2135 · CALPERS RETIREMENT PAYABLE	0.00	
223.70 · WORKERS COMP PAYABLE	0.00	
223.75 · PAYROLL DEDUCTION - INS CO-PAY	12,264.24	
223.80 · GASB 68 Pension		26,313.00
223.85 · MISC DEDUCTIONS PAYABLE		6,993.77
223.90 · COMPENSATED EMPLOYEE BENEFITS		72,925.02
24000 · Payroll Liabilities	16,126.11	
295 · NET PWNSION LIABILITY		1,032,862.00
226 · USDA Int Pymnt-Swr Clarifier	0.00	
225 · USDA Payment - Sewer Clarifier	0.00	
281 · BOND PAYABLE	371,172.41	
302 · RETAINED EARNINGS		3,357,835.60

311

Clearlake Oaks County Water District

Trial Balance

As of July 31, 2023

	Jul 31, 23	
	Debit	Credit
304 · Opening Balance Equity	584,283.24	
306 · Retained Earnings - OLD		16,335,591.17
Income:445 · Bulk Water		36,293.00
Income:410 · Client Reg Pmt		217,961.73
Income:425 · CRP		80,615.03
Income:430 · Penalty & Interest		6,383.80
Income:450 · Other - Non S/W Rev		78.85
Loans/Grants:945 · Wastewater I and I Phase IV	344.00	
Loans/Grants:940 · TA Grant	1,577.50	
Salaries & EE Benefits:545 · CALPers 457	262.50	
Salaries & EE Benefits:505 · Salaries & Wages	115,508.85	
Salaries & EE Benefits:520 · FICA - District Share	8,581.38	
Salaries & EE Benefits:530 · Med/Life Insurance- Dist S...	23,049.76	
Salaries & EE Benefits:540 · PERS - District Share	15,087.34	
Salaries & EE Benefits:560 · Workers Comp Ins	0.00	
Services & Supplies:610 · Bank Fees	3,044.42	
Services & Supplies:620 · Communications & Internet	3,162.25	
Services & Supplies:640 · Fuel & Oil	2,001.14	
Services & Supplies:645 · Insurance	33,027.50	
Services & Supplies:650 · Interest	585.39	
Services & Supplies:657 · Lab	3,055.73	
Services & Supplies:660 · Memberships & Subscription	475.10	
Services & Supplies:675 · Professional Services	9,734.16	
Services & Supplies:685 · Rents	1,743.79	
Services & Supplies:690 · Safety & Security	520.29	
Services & Supplies:700 · Tools & Instruments	56.98	
Services & Supplies:703 · Supplies - Clothing & Personal	993.81	
Services & Supplies:705 · Supplies - Office	907.41	
Services & Supplies:715 · Supplies-Chemicals-Operating	5,692.08	
Services & Supplies:720 · Supplies - Inventory - Other	192.65	
Services & Supplies:750 · Utilities	57,130.63	
Services & Supplies:760 · Waste Disposal	11,279.91	
Services & Supplies:798 · Customer Refund	1,247.93	
Repairs & Replacement:810 · R&R Buildings & Grounds	565.39	
Repairs & Replacement:830 · R&R Equipment	95.42	
Repairs & Replacement:832 · R&R Mains and Sewer Lin...	365.73	
Repairs & Replacement:840 · R&R Vehicles	14,161.97	
TOTAL	<u>40,546,171.74</u>	<u>40,546,171.74</u>

Account Payable Breakdown

Date: 8/14/2023

	<u>QuickBooks</u>	<u>WAB Balance</u>	<u>WAB Available</u>
General Ledger - 9122	\$933,074.29	\$920,212.09	\$930,375.92
CRP Water - 6990	\$92,859.08	\$92,859.08	\$92,859.08
CRP Sewer - 3745	\$119,601.32	\$119,601.32	\$119,601.32
CRP PC - 6192	\$98,605.34	\$98,605.34	\$98,605.34
Water Reserve - 8503	\$174,949.73	\$174,949.73	\$174,949.73
Sewer Reserve - 9592	\$137,994.43	\$137,994.43	\$137,994.43
CalPers Reserve - 7355	\$88,351.77	\$88,351.17	\$88,351.17
LAIF Balance	\$290,488.28	\$1,090,488.28	\$1,090,488.28
Current A/P Aging	\$38,956.85		
Kansas State Bank-VacCon	\$7,421.47	8/15/2023	
Kansas State Bank-Water Truck	\$1,730.25	8/20/2023	
TOTAL	\$48,108.57		
 Paid On-line/Auto Out			
7/31/2023 Cannon	\$680.59		
8/7/2023 PG&E	\$31,058.95		
7/27/2023 Credit Card	\$10,859.12		
8/9/2023 Bluefin	\$56.25		
7/31/2023 Mediacom	\$310.72		
TOTAL-Paid On-line/Auto Out	\$42,965.63		

7:14 AM

08/14/23

Clearlake Oaks County Water District
A/P Aging Summary
As of August 14, 2023

	Current	1 - 30	31 - 60	61 - 90	> 90	TOTAL
ACWA/JPIA - W/C & Liab	0.00	0.00	15,840.25	0.00	0.00	15,840.25
Alpha Analytical Labs	2,725.00	0.00	0.00	0.00	0.00	2,725.00
Badger Meter	139.45	0.00	0.00	0.00	-5,042.36	-4,902.91
California State Disbursement Unit	530.76	0.00	0.00	0.00	0.00	530.76
Clearlake Lava	1,308.46	0.00	0.00	0.00	0.00	1,308.46
Colony Products	697.12	0.00	0.00	0.00	0.00	697.12
County of Lake	1,900.00	0.00	0.00	0.00	0.00	1,900.00
County of Lake - Water Resources Dept.	0.00	100.04	0.00	0.00	0.00	100.04
Deeper Cleaning	490.00	0.00	0.00	0.00	0.00	490.00
Docufree Corporation	4,500.00	0.00	0.00	0.00	0.00	4,500.00
Garrett Swanz.	129.51	0.00	0.00	0.00	0.00	129.51
Independant Business Forms	260.27	0.00	0.00	0.00	0.00	260.27
James N Brackens	228.12	0.00	0.00	0.00	0.00	228.12
Jeff Moroni	56.77	0.00	0.00	0.00	0.00	56.77
Kelseyville Lumber	58.98	46.11	0.00	0.00	0.00	105.09
Lake Fleet Repair & Tow	13,035.71	0.00	0.00	0.00	0.00	13,035.71
Napa Auto Parts	67.75	83.34	0.00	0.00	0.00	151.09
Quill	199.80	0.00	0.00	0.00	0.00	199.80
Redwood Coast Fuels	0.00	876.66	0.00	0.00	0.00	876.66
Terminix	0.00	150.00	0.00	0.00	0.00	150.00
Thomas Stewart	275.11	0.00	0.00	0.00	0.00	275.11
USA North 811	300.00	0.00	0.00	0.00	0.00	300.00
TOTAL	26,902.81	1,256.15	15,840.25	0.00	-5,042.36	38,956.85

CLEARLAKE OAKS COUNTY WATER DISTRICT

NOTICE OF A REGULAR MEETING OF THE BOARD OF DIRECTORS

Date: July 20, 2023

Time: 2:00 P.M.

Clearlake Oaks County Water District Administration Building
12952 E. Hwy. 20 Clearlake Oaks, CA 95423

MINUTES

A. CALL TO ORDER

- Pledge of Allegiance
- Roll Call

√ Mr. Stanley Archacki, Vice President √ Mr. Samuel Boucher, Director □ Mr. Michael Herman, Director, **EXCUSED** √ Mr. James Burton, Director √ Mr. William McHugh, Director √ Mrs. Dianna Mann – General Manager √ Mrs. Olivia Mann – Board Secretary

□ Mr. Francisco Castro, Wastewater, **EXCUSED** √ Mr. Kurt Jensen, Water √ Mr. Jeremy Backus, Distribution

B. PUBLIC COMMENT ON ITEMS NOT ON THE AGENDA

The public may comment on items not on the agenda within the Board's jurisdiction. Speakers are limited to three (3) minutes each.

C. STAFF REPORTS

1. Administration
2. Chief Distribution Operator
3. Chief Water Plant Operator
4. Chief Wastewater Plant Operator
5. General Manager

D. CONSENT ITEMS

The Board will be asked to approve all Consent Items at one time without discussion. If any Director, staff, or interested person requests that an item be removed from the Consent Items, it will be considered under New Business.

1. Financial Reports for review and approval

- a. June 2023 QB balance sheet and profit & loss statements
- b. Bank account balances and accounts receivable
- c. Employee payroll report
- d. Aged trial balance summary
- e. Vendor aging report, accounts payable breakdown

2. **Minutes of previous meeting for review and approval**

- a. Minutes of Regular Meeting 06/15/2023 (*Page 45*)
- b. Minutes of Special Meeting 07/13/2023 (*Page 48*)

3. **Bills**

- a. T & S Construction invoice number 24, dated 6/30/23, in the amount of \$24,301.14 for the USDA Water Project (*Page 49*)
- b. MC Engineering invoice number 2418, dated 7/6/23, in the amount of \$2,106.27 for the USDA Water Project (*Page 50*)

Action Taken: Motion to approve the consent items
BOUCHER/BURTON M/S/C
AYES: ARCHACKI/BOUCHER/BURTON
NOES: NONE
ABSENT: HERMAN

E. NEW BUSINESS

- 1. Appoint and Administer Oath of Office to Director William McHugh

Action Taken: Motion to appoint Director William McHugh

Administered Oath of Office

HERMAN/BOUCHER M/S/C
AYES: ARCHACKI/BOUCHER/BURTON
NOES: NONE
ABSENT: HERMAN

- 2. Nominations and Elections of Board President and Vice President

Action Taken: Motion to nominate and elect Director Stanley Archacki as President and Director Michael Herman as Vice President
BOUCHER/MCHUGH M/S/C
AYES: ARCHACKI/BOUCHER/BURTON/MCHUGH
NOES: NONE
ABSENT: HERMAN

- 3. Discussion and consideration of 23-09, Approving the Revised Sewer System Management Plan (*Page 51*)

Action Taken: Motion to approve Resolution 23-09, Approving the Revised Sewer System Management Plan
BURTON/BOUCHER M/S/C
AYES: ARCHACKI/BOUCHER/BURTON/MCHUGH
NOES: NONE
ABSENT: HERMAN

4. Discussion and consideration of 23-10, Expressing Appreciation to Mary Margaret Medeiros *(Page 52)*

Action Taken: Motion to approve Resolution 23-10, Expressing Appreciation to Mary Margaret Medeiros
BURTON/MCHUGH M/S/C
AYES: ARCHACKI/BURTON/MCHUGH
NOES: NONE
ABSTAIN: BOUCHER
ABSENT: HERMAN

5. Discussion and consideration of sending the General Manager and Board Secretary to attend the 2023 CSDA Board Secretary Conference

Action Taken: Motion to send the General Manager and Board Secretary to attend the 2023 CSDA Board Secretary Conference
BURTON/BOUCHER M/S/C
AYES: ARCHACKI/BOUCHER/BURTON/MCHUGH
NOES: NONE
ABSENT: HERMAN

6. Discussion and consideration of approving the engagement letter from Pehling & Pehling CPA to conduct the 2022-2023 annual audit in the amount of \$12,800.00, with 50% due upon approval *(Page 53)*

Action Taken: Motion to approve the engagement letter from Pehling & Pehling CPA to conduct the 2022-2023 annual audit in the amount of \$12,800.00, with 50% due upon approval
BURTON/BOUCHER M/S/C
AYES: ARCHACKI/BOUCHER/BURTON/MCHUGH
NOES: NONE
ABSENT: HERMAN

7. Discussion and consideration of giving the General Manager permission to use funds from the CRP Water, CRP Sewer, CalPERS, Water Reserve, Sewer Reserve and LAIF Restricted Accounts to pay litigation obligations

Action Taken: Motion to allow the General Manager to use funds from the CRP Water, CRP Sewer, CalPERS, Water Reserve, Sewer Reserve and LAIF Restricted Accounts to pay litigation obligations
BOUCHER/MCHUGH M/S/C
AYES: ARCHACKI/BOUCHER/BURTON/MCHUGH
NOES: NONE
ABSENT: HERMAN

F. CLOSED SESSION

1. Pending Litigation: One Case

*** NO CLOSED SESSION**

ADJOURNMENT

Time: 2:43 PM

SIGNED: _____ **ATTESTED TO:** _____
Stanley Archacki, President **Olivia Mann, Board Secretary**

Where appropriate or deemed necessary, the Board may take action on any item listed on the agenda, including items listed as information items. Public documents relating to any open session item listed on this agenda that are distributed to all or a majority of the members of the Board of Directors less than 72 hours before the meeting are available for public inspection in the customer service area of the District's Administrative Office at the above address.

The public may address the Board concerning an agenda item during the Board's consideration of that agenda item. The President will call for comments at the appropriate time. Comments of individual speakers are limited to three minutes per agenda item.

In compliance with the Americans with Disabilities Act, if you have a disability, and you need a disability-related modification or accommodation to participate in this meeting, then please contact Clearlake Oaks County Water District Secretary to the Board at 707-998-3322. Requests must be made as early as possible, and at least one full business day before the start of the meeting.



MC Engineering, Inc.

9294 Madison Ave
Orangevale, CA 95662

Invoice

Date	Invoice #
8/5/2023	2437

Bill To

Clearlake Oaks Water District
12545 Highway 20
Clearlake Oaks, CA 95423

Job No.	Terms	Due Date	Project	
	Net 30	9/4/2023	SWRCB Water TA Grant	
Description		Qty	Rate	Amount
Engineering Tech, Julia Asbenson		2.5	105.00	262.50
Project Engineer, Jared P. Nelson		62.5	135.00	8,437.50
Assistant Engineering Tech, Joseph Dascenzi		0.5	95.00	47.50
Work included modifying node demands and diurnal patterns to generate 2023 system demand characteristics.				
Total				\$8,747.50
Payments/Credits				\$0.00
Balance Due				\$8,747.50

Phone #	Fax #	E-mail
916-546-7898	916-860-1863	mark.carey@mc-engineers.com

AA

Diesel Fuel Injection Pump R&R

Number	Type	Part#/Op Code	Description	Quantity	Unit Price	Total Cost
21	Part		4C3Z*8501*C PUMP ASY	1.00	\$ 254.55	\$ 254.55
22	Part		3C3Z*8575*AA THERMOSTAT	1.00	\$ 39.69	\$ 39.69
23	Part		4C3Z*6K682*CDRM REMAN TURB	1.00	\$ 1,299.37	\$ 1,299.37
24	Part		delo	14.00	\$ 11.00	\$ 154.00
25	Part		oil filter	1.00	\$ 20.00	\$ 20.00
26	Part		coolant	3.00	\$ 34.00	\$ 102.00
27	Part		inner cooler	1.00	\$ 1,158.33	\$ 1,158.33
28	Part		glow plug harness	2.00	\$ 79.53	\$ 159.06
29	Part		air intake tube	1.00	\$ 111.00	\$ 111.00
30	Labor	Diesel Fuel Injection Pump R&R	Fuel Injector R&R - Without Dual Alternator - Left and Right - Both Sides	20.0000	\$ 130.0000	\$ 2,600.00
Job Total:						\$ 12,186.86

Total Labor Time: 20.0000 Hours Total Jobs Cost: \$ 12,186.86

Approved
000
11/13/23
11/13/23

Parts	\$ 9,586.86
Labor	\$ 2,600.00
Tax	\$ 838.85
Shop Supplies & Hazardous Materials	\$ 10.00
Grand Total	\$ 13,035.71
Balance Due	\$ 13,035.71

Board Approved RM 5/18/23

8/10/CRP W/S

Revision History

Jul 20, 2023 @ 2:35 PM Revision 1: Job Approved by Joseph Szupello, authorized by Jeremy water dist via Phone Call
 Diesel Fuel Injection Pump R&R
 Price Increased from \$10.00 to \$13,035.71

I have received the above goods and/or services. If this is a credit card purchase, I agree to pay and comply with my cardholder agreement with the issuer. also all re-main transmission come with a 3 year unlimited mile warranty, all other repairs come with a 18 month 18k mile warranty.

A finance charge of 10%/mo (18% annual rate) will be charged on all past due accounts. All parts are new unless otherwise specified. Re-check torque after the first 50 to 100 miles of service.

Signature: _____ Date: _____



clearlake oaks water dist.

Jeremy water dist
CA
+1 (707) 350-5622
m.johnson@clowd.org

Lake Fleet Repair & Tow
1701 N. High St.
Lakeport, CA 95453
Phone: (707) 413-3429
Fax: (707) 413-3430
lakefleetrepair@hotmail.com

VIN: 1FDAF56P24EB73334
Vehicle: 2004 Ford F-550
Super Duty XL 6.0L,
V8, Diesel, Asp T, VIN
P, 32V, OHV,
USA/Canada

License: 1173071
Odometer: 30,000 Miles

Customer
Notes:

Invoice: 002373
Created: 07/20/2023 2:35 PM
Printed: 07/20/2023 2:35 PM
Technician(s): Ford Mike
Written by: Joseph Szupello

Diesel Fuel Injection Pump R&R

Number	Type	Part#/Op Code	Description	Quantity	Unit Price	Total Cost
1	Part		8C3Z*12K073*A SENSOR - C	1.00	\$ 51.40	\$ 51.40
2	Part		HC3Z*12B599*GRM REMAN MODU	1.00	\$ 616.67	\$ 616.67
3	Part		4C3Z*9J460*A SENSOR ASY	1.00	\$ 147.64	\$ 147.64
4	Part		3C3Z*9C968*AA REGULATOR	1.00	\$ 425.45	\$ 425.45
5	Part		4C3Z*9F838*A SENSOR ASY	1.00	\$ 186.67	\$ 186.67
6	Part		4C3Z*9E527*ARM REMAN INJE	8.00	\$ 247.14	\$ 1,977.12
7	Part		4C3Z*12A342*A GLOW PLUG	8.00	\$ 23.82	\$ 190.56
8	Part		NT-EGRC-1 BP EGR COO	1.00	\$ 425.00	\$ 425.00
9	Part		4C3Z*9F452*B VALVE ASY	1.00	\$ 332.73	\$ 332.73
10	Part		4C3Z*9A543*AARM REMAN PUMP	1.00	\$ 751.43	\$ 751.43
11	Part		3C3Z*6A642*CA KIT	1.00	\$ 439.83	\$ 439.83
12	Part		3C3Z*9N184*CB ELEMENT	1.00	\$ 96.16	\$ 96.16
13	Part		3C3Z*6C315*AA SENSOR - C	1.00	\$ 62.38	\$ 62.38
14	Part		3C3Z*6584*BA GASKET -V	1.00	\$ 50.46	\$ 50.46
15	Part		4C4Z*8592*AA CONNECTION	1.00	\$ 49.73	\$ 49.73
16	Part		4C3Z*9601*AA ELEMENT AS	1.00	\$ 148.00	\$ 148.00
17	Part		3C3Z*8620*DB V-BELT	1.00	\$ 79.45	\$ 79.45
18	Part		7C3Z*8678*B KIT - TENS	1.00	\$ 52.36	\$ 52.36
19	Part		3C3Z*8678*EB KIT - TENS	1.00	\$ 61.09	\$ 61.09
20	Part		3C2Z*6B209*AA TENSIONER	1.00	\$ 144.73	\$ 144.73
Job Total:						\$ 12,186.86

Signature: _____

Date: _____

40

RYAN PROCESS



WASTEWATER, WATER & PROCESS SPECIALISTS

RYAN PROCESS QUOTE FORM

DATE OF THIS QUOTE: 7/26/2026

RYAN PROCESS QUOTE # CLOW072623dwrev

MAIN OFFICE PHONE: (925) 837-0670 QUOTE VALID FOR: 3 WEEKS

511 1ST STREET BENICIA, CA 94510 *This Quote Prepared by:* DAVE WHITE

SALES PERSON EMAIL: dw@ryanprocess.com

QUOTE TO: SALES PERSON PHONE#: (925) 837-0670

CLEARLAKE OAKS WATER & SANITATION DEPT. PROJECT DESCRIPTION:

SII 2500 DCT for bleach

NAME Contact: FRANCISCO CASTRO

EMAIL Contact: f.castro@clowwd.org

PHONE#: (707) 350-0719

RPI TERMS F.O.B. Ship Via Shipping Terms

NET 20, ADD 1.5%/MO FACTORY BEST WAY BEST WAY

AFTER 30 DAYS

ITEM #	DESCRIPTION	Qty.	UNIT PRICE	EXT PRICE
--------	-------------	------	------------	-----------

5580000N	Snyder 2500 CCS double containment tank, 102x122, HDPE resin, 1.9 sp gr, 18" vented manway	1		\$10,910.00
----------	--	---	--	-------------

ACCESSORIES TO INCLUDE

880059	HYPOCHLORITE WHITE RESIN ADDER-REQUIRED-REDUCES TEMP IN TANK ANNULAR SPACE REDUCING OFF GASSING	1		\$2,151.00
--------	---	---	--	------------

1070000N-2V	2" UFO PVC/VITON TANK TRANSITION FITTING (OUTLET)	1		\$591.00
-------------	---	---	--	----------

34700687	2" PVC DOUBLE FLANGE ADAPTOR W/IT TITANIUM BOLTS(OUT)	1		\$716.00
----------	---	---	--	----------

34700861	2" PVC SLIP FIT FLANGE ADAPTOR (OUTLET)	1		\$42.00
----------	---	---	--	---------

34701257	2" PVC SLIP FIT SIPHON TUBE (OUTLET)	1		\$63.00
----------	--------------------------------------	---	--	---------

34700264	4" PVC BULKHEAD FITTING WITH U-VENT	1		\$494.00
----------	-------------------------------------	---	--	----------

34700901	MESH BUG SCREEN FOR U-VENT	1		\$20.00
----------	----------------------------	---	--	---------

34700238	2" PVC BULKHEAD FTG W/VITON GSKT (FILL)	1		\$107.00
----------	---	---	--	----------

347	2" PVC EXTERNAL FILL PIPE W/GROUND SUPPORT (FILL)	1		\$460.00
-----	---	---	--	----------

34700040	SIGHT GLASS ASSEMBLY WITH VITON GASKET	1		\$182.00
----------	--	---	--	----------

5390100N95401	2" HDPE FLEXMASTER FLEX COUPLING	1		\$481.00
---------------	----------------------------------	---	--	----------

33100021	2" VITON GASKETS FOR FLEX CONNECTOR	2		\$215.00
----------	-------------------------------------	---	--	----------

171	TANK WRAP FOR SHIPMENT	1		\$108.00
-----	------------------------	---	--	----------

OPTIONAL

34701030	LEAK DETECTION SENSOR (SEE ATTACHED)	1		\$400.00
----------	--------------------------------------	---	--	----------

--	--	--	--	--

--	--	--	--	--

--	--	--	--	--

--	--	--	--	--

EST. Lead Time:	ESTIMATE 10 WEEKS AFTER DRAWING APPROVAL	Subtotal	\$16,940.00
-----------------	--	----------	-------------

SPECIAL NOTES:	SHIPS FROM LINCOLN NB, FREIGHT IS COMBO LOAD PRICING	FREIGHT EST	2300.00
----------------	--	-------------	---------

**All prices are in U.S. Dollars.		SALES TAX	\$1,228.50
-----------------------------------	--	-----------	------------

**Any credit card payments require a 5% handling fee. We accept Visa and Mastercard		TOTAL	\$20,468.50
---	--	-------	-------------

**Standard Ryan Process Terms:	50/20 REMAINDER NET 30		
--------------------------------	------------------------	--	--

**UNLESS OTHERWISE STATED Freight and Sales Taxes not included in pricing.			
---	--	--	--

M

The leak detector unit consist of a proximity sensor, a welded 2 inch FPT connection, a 2 inch bung plug with a 3/4 inch strain relief, and an indicator box. The sensor is placed in the interstitial space between the primary and secondary tanks approximately 1 inch above the tank bottom. The indicator box is NEMA 4X rated and factory pre-wired for 110 VAC power. All connections are labeled to prevent errors in field installation. The indicator box will show a green light when power is on and the sensor is not detecting a liquid. The light is a push to test light allowing the operator to test for power outage or malfunction. If the green light goes out there are two possibilities. The green light does not come on when the button is pushed would indicate a lack of power to the unit or the light bulb is burned out. If the green light comes on when pushed, then a possible leak condition is indicated.



- **Rated operational voltage: 110 VAC only**
- **Adjustable sensing distance 2-16 mm**
- **Output: SCR**
- **Make and break switching function**
- **LED indication**
- **High noise immunity**

Specifications

Rated operating dist. (S_n) 3016:	2 to 16 mm factory set at 16 mm	Power ON delay	≤ 100 ms
Sensitivity	Adj. multiturn pot. meter	Frequency of operating cycles (f)	10 Hz
Effective operating dist. (S_r)	0.9 x S _n ≤ S _r ≤ 1.1 x S _n	Indication for output ON	LED, yellow
Usable operating dist. (S_u)	0.8 x S _r ≤ S _u < 1.2 x S _r	Environment	
Repeat accuracy (R)	≤ 5%	Degree of protection	IP 67 (Nema 1, 3, 4, 6, 13)
Hysteresis (H)	4 to 20% of sensing distance	Temperature	
Rated operational volt. (U_B)	20 to 250 VAC (ripple included)	Operating temperature	-25° to +80°C (-13° to +176°F)
Ripple	≤ 10%	Storage temperature	-40° to +85°C (-40° to +185°F)
Rated operational current (I_e)		Housing material	
Continuous	≤ 500 mA	Body	Grey, thermoplastic polyester
Short-time	< 2.5 A (max. 20 ms)	Cable end	Polyester
Min. load current	≤ 10 mA	Nuts	Black reinforced nylon
OFF-state current (I_o)	< 2.5 mA (@ 240 VAC) 1.7 mA (@ 120 VAC)	Connection	
Voltage drop (U_d)	≤ 10 VAC (at loads ≥ 20 mA)	Cable	Grey, 2 m, 2 x 0.5 mm ²
Protection	Transients	Plug (-6)	Oil proof, PVC
		Cable for plug (-6)	M12 x 1 double keyed CON.-6A-series
		Weight (incl. nuts)	3016: 140 g
		Approvals	UL, CSA
		CE-marking	Yes

Specifications are subject to change without notice (20.08.01)

Ø 1.06 TYP.
 18" PE THREADED/VENTED
 MANWAY w/15" ACCESS
 5.3
 LADDER LUGS
 @ 0° & 180°

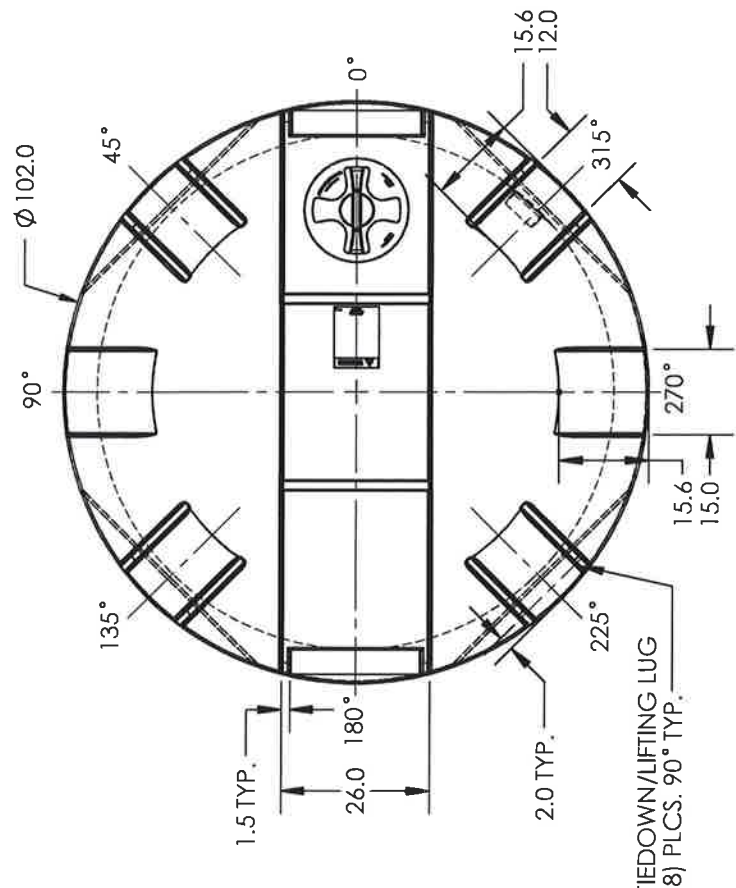
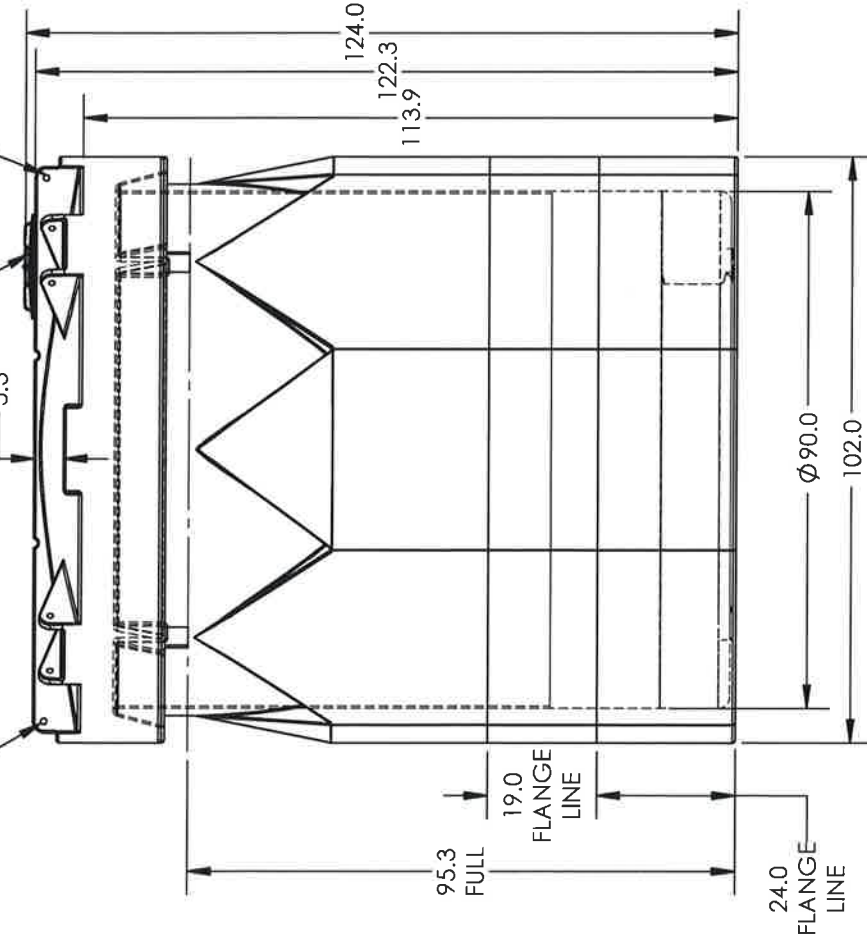

***ALL EXTERNAL PIPING MUST BE INDEPENDENTLY SUPPORTED.**
***ONLY BASE FITTINGS TO BE LEFT INSTALLED AT TIME OF SHIPMENT PER SII PROCEDURE.**
***TANKS ORDERED WITH FOAM INSULATION WILL HAVE AN INCREASED DIAMETER OF 4-6 INCHES.**
***Consult Snyder's Guidelines for Use and Installation prior to delivery.**
 Available on-line at <http://www.snyderindustriestanks.com/technical>
ALL DIMENSIONS ARE IN INCHES, NOMINAL, & SUBJECT TO CHANGE WITHOUT NOTICE.
ALL DIMENSIONS ON ROTATIONAL MOLDED PARTS ARE SUBJECT TO A ± 3% TOLERANCE.

DO NOT SCALE	DRAWN BY	REVISED
Released	E13	A
© SNYDER INDUSTRIES, LLC, 2018		SHEET
TITLE		1 OF 1
ASM TK 2500 CCS		
PART NO. 5580000N & 5510000N		ENG. ID. A003552
(402) 467-5221		
www.snyderintl.com		
<small>ALL DIMENSIONS, DESIGNS, AND INFORMATION ON THE PRINT MUST BE USED, COPIED, OR REPRODUCED IN ANY MANNER WITHOUT WRITTEN PERMISSION OF AN OFFICER OR HIS AGENT OF THE FRM.</small>		

CLEARLAKE OAKS COUNTY WATER DISTRICT

P.O. Box 709, 12952 E. HWY. 20

CLEARLAKE OAKS, CA 95423

(707) 998-3322

RESOLUTION NO. 23-11

**RESOLUTION TO TRANSFER DELINQUENT ACCOUNT
BALANCES TO THE COUNTY OF LAKE FOR INCLUSION
WITH THE COUNTY'S SECURED TAX COLLECTIONS.**

WHEREAS, the Clearlake Oaks County Water District's Board of Directors has determined that there is a need for assistance in collecting the District's delinquent accounts receivables; and

WHEREAS, the County of Lake has a means of collecting government agency's delinquent accounts by placing direct charges on the secured tax roll for real property within its jurisdiction. (See Attachment A)

NOW, THEREFORE, BE IT RESOLVED THAT, the Clearlake Oaks County Water District herewith requests that the County of Lake place as a lien on the secured tax roll of certain real property within the County of Lake's jurisdiction, the District's delinquent accounts

THE ABOVE RESOLUTION is hereby passed and adopted by the Board of Directors of the Clearlake Oaks County Water District at a special meeting thereof held on the 17th day of August 2023, by the following vote:

AYES:

NOES:

ABSTAIN:

ABSENT:

CLEARLAKE OAKS COUNTY WATER DISTRICT

By: _____
Stanley Archacki, Board President

Attest: _____
Olivia Mann, Board Secretary

LAKE COUNTY AUDITOR-CONTROLLER

FY 2023-2024

SECURED DIRECT ASSESSMENT CERTIFICATION

Deadline: Submit any time, but no later than August 10th

To: Lake County Auditor-Controller
255 North Forbes Street
Lakeport, CA 95451

District Name & Direct Charge #: CLEARLAKE OAKS CO WTR DIST, 90900

Primary Contact Name: Olivia Mann Phone: 707-998-3322

Email: o.mann@clowwd.org

Secondary Contact Name: Phone:

Email:

Total Number of Assessments Charged: 125 Total Sum of Assessments Charged: \$165,789.82

Upon satisfactory proof, Revenue and Taxation (R& T) Code section 4986 authorizes the Auditor to cancel all or any portion of any tax, penalty or cost if it was levied or charged: 1) More than once; 2) Erroneously or illegally; 3) On the cancelled portion of an assessment that has been decreased pursuant to a correction; 4) On property that did not exist on the lien date; 5) On property annexed after lien date by the public entity owing it; 6) On property acquired by a public entity; 7) On that portion of an assessment in excess of the value of the property as determined by the Assessor pursuant to R & T code section 469.

Furthermore, upon the recommendation of the Tax Collector, R & T Code section 4986.8 authorizes the Auditor to cancel "any tax bill if the amount is so small as not to justify the cost of collection. Any penalties, costs, fees, or special assessments....of any tax bill which is cancelled pursuant to this section may also be cancelled." Any tax bill so cancelled will result in an adjustment to current tax apportionments. (See R & T Code section 4707).

The City/District certifies that it has read and understands the above paragraph regarding the potential effect on property tax apportionments if tax bills are cancelled. The City/District also certifies that it has complied with all applicable laws prior to imposing these taxes/fees/assessments and agrees to defend, indemnify, hold harmless and release the County from any and all actions, claims, and damages arising out of or in connection with any claim or lawsuit alleging that the City/District unlawfully imposed the taxes/fees/assessments.

The City/District certifies that the parcel data and taxes/fees/assessments have been updated to the City/District's satisfaction. The City/District requests placement of the City/District's taxes/fees/assessments on the Lake County tax statements and agrees to the County's posted cost recovery per GC 51800.

[X] City/District approval of the complete listing, including all modifications, in electronic form and on hard copy.

Preparer Signature: [Signature] Print Name: Olivia Mann Date: 08/10/2023

Chair/Vice Chair Signature: Print Name: Date:

Please mail the original Direct Assessment Certification form to the address listed above. Email a copy to Peter Bazzano at peter.bazzano@lakecountyca.gov along with the completed electronic listing of your assessments.

CLEARLAKE OAKS COUNTY WATER DISTRICT

P.O. Box 709, 12952 E. Hwy. 20

CLEARLAKE OAKS, CA 95423

(707) 998-3322

RESOLUTION NO. 23-12

**A RESOLUTION OF THE BOARD OF DIRECTORS
OF THE CLEARLAKE OAKS COUNTY WATER DISTRICT**

**AUTHORIZING INVESTMENT OF MONIES
IN THE LOCAL AGENCY INVESTMENT FUND**

WHEREAS, The Local Agency Investment Fund is established in the State Treasury under Government Code section 16429.1 et. seq. for the deposit of money of a local agency for purposes of investment by the State Treasurer; and

WHEREAS, the Clearlake Oaks County Water District Board of Directors hereby finds that the deposit and withdrawal of Clearlake Oaks County Water District monies in the Local Agency Investment Fund in the State Treasury in accordance with Government Code section 16429.1 et. seq. for the purpose of investment as provided within.

BE IT FURTHER RESOLVED, as follows:

Section 1. The following Clearlake Oaks County Water District officers holding the title(s) specified herein below or their successors in office are each hereby authorized to order the deposit or withdrawal of monies in the Local Agency Investment Fund and may execute and deliver any and all documents necessary or advisable in order to effectuate the purposes of this resolution and the transactions contemplated hereby:

Stanley Archacki
Board President

Michael Herman
Vice President

Samuel Boucher
Director

James Burton
Director

(SIGNATURE)

(SIGNATURE)

(SIGNATURE)

(SIGNATURE)

William McHugh
Director

Dianna Mann
General Manager

Olivia Mann
Board Secretary

(SIGNATURE)

(SIGNATURE)

(SIGNATURE)

THE ABOVE RESOLUTION is hereby passed and adopted by the Board of Directors of the Clearlake Oaks County Water District at a Regular Meeting thereof held on the 17th day of August 2023, by the following vote:

AYES:

NOES:

ABSTAIN:

ABSENT:

CLEARLAKE OAKS COUNTY WATER DISTRICT

By: _____
Stanley Archacki, Board President

Attest: _____
Olivia Mann, Board Secretary

